

SNJB (Jain Gurukul's)

K.K.H. Abad Arts, S.M.G. Lodha Commerce & S.P.H. Jain Science College
Neminagar, Chandwad-423101, Dist.-Nashik, Maharashtra



Establishment
27/11/1928

(Affiliated to Savitribai Phule Pune University) Id. No.PU/NS/AC/015/1970

(02556) Off. 252125 Res.252126 Tel. Fax:02556-252125

• P. O. Box No.: 6 • E-mail : alccchandwad@yahoo.co.in

• Website : www.acschandwadcollege.com

DST-FIST Funded (2018-19)

UGC-NSQF Courses (B.Voc. & CC)

Best College Award by Savitribai Phule Pune University (2015-16)

4.1.1 Instrument List with Photos

INDEX

Sr. No.	Description	Total No of Instruments	Page No.
1.	Chemistry	131	2-4
2.	Botany	115	5-6
3.	Physics	100	7-9
4.	Electronic Science	17	9-10
5.	Zoology	26	10
6.	DMLT	09	10
7.	Geography	13	10-11
8.	Instrument Images	-	12-112

Sr.No	Name of Equipment	Specifications	Make	Quantity	Funded By
DEPARTMENT OF CHEMISTRY					
01	Flame Photometer	Range: 0-100 ppm for Na 0-100 ppm For K	ESICO	01	MRP-BCUD
02	Digital Melting Point App.	Temp range: 0 °C to 300 °C	EI	01	MRP-UGC
03	Digital Melting Point App.	Temp. range : 0 °C to 300°C	STURT	01	MRP-UGC
04	Digital Melting Point App.	Temp. range - 0 °C to 300 °C	DBK	01	MRP-BCUD
05	Digital Magnetic Stirrer With Hot Plate	Speed:100-1500 rpm Temp: 0 to 340 °C	Remi	01	MRP-UGC
06	Muffle Furnace	Size: 25x13x13 cm Standard Working Temperature: 1600 °C	Labline	01	MRP-UGC
07	Digital Balance	Acc.: 0.0001gm	Contech	01	MRP-UGC
08	Nephelometer	Range: 0-1000 NTU	Systronics	01	INSTITUTE
09	Polarimeter	Detection of angle of rotation = +200 degree (Acc. = +1 deg.)	Equip-tronics	01	INSTITUTE
10	Spectrophotometer	Range: 340 nm to 999 nm	Systronics	01	INSTITUTE
11	Photoflurometer	Upto 0.1 ppm detection	Systronics	01	INSTITUTE
12	Conductivity meter	Range: 01m to 200 mm in Six ranges. Acc.: +1%	Equip-Tronics	04	INSTITUTE
13	Colorimeter	Transmittance (T): 0-100% Selenium Photo Cell	Equip-Tronics	04	INSTITUTE
14	Potentiometer	Full Scale Count: 1.999 Volts, Acc: 0.0001 Volts, Resolution: 1-2000	Equip-Tronics	04	INSTITUTE
15	pH Meter	Range: 0 to 14.00 pH 0 to +1999 mV	Equip-Tronics	04	INSTITUTE
16	pH Meter	Range: 0 to 14.00 pH 0 to +1999 mV	Equip-Tronics	01	MRP-BCUD
17	Magnetic Stirrer	Stirring Capacity: 2 Ltr. External Dimension- 150 x 220 x 150, X Length-9 x 35 mm	Remi	10	INSTITUTE
18	Hot Air Oven	Temp Range: 50 °C to 250 °C	Labline	01	INSTITUTE
19	Hot Air Oven	Temp Range-50°C to 250°C	Bio Technics	01	INSTITUTE
20	Water Bath	TempRange-30 °C to 100 °C, Size: 14 X 10X 4	Labline	01	INSTITUTE

21	Digital Water Bath	Temp Range: 50 °C to 250°C , Acc: +/-2 °C	Bio Technics	03	INSTITUTE
22	Round Water Bath	Temp Range: 50 °C to 250 °C, Acc: +/-2 °C	Coslab	01	MRP-BCUD
23	Magnetic Stirrer with Hot Plate	Stirring Capacity: 2 Ltr. Heating Capacity: 300 Watt,	Remi	05	MRP-BCUD
24	Magnetic Stirrer with Hot Plate	Stirring Capacity: 2 Ltr. Heating Capacity: 300 Watt,	Remi	10	INSTITUTE
25	Centrifuge Machine	Speed: 3500 rpm, Weight-5 kg	Remi	02	INSTITUTE
26	Digital Balance	Cap: 300 gm, Acc.: 0.01 gm	Aczel	01	INSTITUTE
27	Digital Analytical Balance	Cap.: 220 gm, Sens: 0.001gm	Contech	02	INSTITUTE
28	Digital Balance	Cap: 300 gm, Acc: 0.01 gm	Citizen	06	INSTITUTE
29	Distillation Plant	Cap: 4 Ltr.	Bio Technics	01	INSTITUTE
30	Distillation Plant	Cap: 4 Ltr	Mod. Science	01	INSTITUTE
31	Heating Mantle	500 ml & 500 ml Temp: 1 °C to100 °C	Mod. Science	500 ml- 02 250 ml-02	INSTITUTE
32	Abbe Refractometer	Resolution: 1 % , Acc: 0.2 % , Wt - 4.2 kg	RSR	01	INSTITUTE
33	Heating Mantle	500 ml & 500 ml Temp: 1 °C to100 °C	Mod. Science	500 ml- 02 250 ml-02	INSTITUTE
34	Abbe Refractometer	Resolution -1 % , Acc:0.2 % , Wt - 4.2 kg	RSR	01	INSTITUTE
35	Abbe Refractometer	Resolution-1% , Acc-0.2% ,Wt-4.2 kg	Coslab	01	INSTITUTE
36	UV Cabinet	Short UV-254 nm, Long UV-365nm &Visible Light	Labline	03	MRP-BCUD
37	UV Cabinet	Short UV-254 nm, Long UV-365nm &Visible Light	---	01	INSTITUTE
38	IR-Lamp		Modern India	05	INSTITUTE
39	pH Meter Pen Type	pH range: 1 to 14	Henna	03	MRP-BCUD
40	Water Bath Round Cap	230 Volt, Watt-1000	Bio Technics India	01	MRP-UGC
41	Vacuum Pump	Pressure-25 psi, Speed-1440 rpm	--	03	INSTITUTE
42	Vaccum Pump	Power-1/4 HP, Free air displacement-2.0 CEF	Valve	01	INSTITUTE
43	Vacuum Pump	Flow-45, Vaccum-27, Pressure-55,Speed-1440, Motor-1/4	CE	01	MRP-UGC
44	Hot Plate Reading	Size-10x12, 230 Volts, 1200 Watt Thermostat	Labline	02	MRP-UGC
45	Heating Mantle 5	500 ml , Tem:- 1 °C to100 °C	Labline	04	MRP-UGC
46	FTIR-Affinity 1 SWL	Wavenumber range-7,800 to 350 cm ⁻¹ Resolution-0.5,1,2,4,8,16 cm ⁻¹ Dimension-514(W) x 606(D) x 273(H) mm	Shimadzu	01	INSTITUTE

		Weight-35 Kg			
47	UV-VISIBLE (2600)	Wavenumber range-220nm to 1400nm Wavelength repeatability- +0.05nm Resolution-0.1 nm Dimension- W450xD600xH250 (mm) Weight-23 Kg	Shimadzu	01	INSTITUTE
PIRAMAL					
48	Rota Evaporator	Rotation speed -(min ⁻¹)20-280 Heating Capacity- (W)-1300 W x D x H - (mm)=550x415x575	BUCHI	03	PIRAMAL
49	Vacuum Pump	Oil Sealed,RPM-500,Reco HP./KW.0.5	ARUNVAK	02	PIRAMAL
50	Vacuum Pump	Stage-2, DISPT-150,ULT. VAC-0.005	ARUNVAK	01	PIRAMAL
51	Vacuum Pump	RPM-500, Reco HP./KW.0.5	WELCH	01	PIRAMAL
52	Hydrogenation Apparatus	Maximum Pressure: 60 psi, Temp: 80 °C, Dimensions: Base Plate: 22 x 19 in. Overall Height: 14 in.	PARK SHAKER	01	PIRAMAL
53	IR-Hydraulics Pressed Apparatus	Ideal for FTIR, KBr and XRF sample preparation	PERKIN-ELEMER	01	PIRAMAL
54	Vari Temp-Heat Gun	Temp. range : Upto 550 °C	MASTER APLLINCE	01	PIRAMAL
55	Fuming Hood with Blower	4 Feet x 4 Feet	KEWAUNEE	02	PIRAMAL
56	Magnetic Stirrer with Hot Plate	Stirring Capacity: 2 Ltr. Heating Capacity-300 Watts, Speed-100 to 1500 rpm	LAB COMPANION	01	PIRAMAL
57	Magnetic Stirrer with Hot Plate	Stirring Capacity: 2 Ltr. Heating Capacity: 300 Watt	DEEPLI	01	PIRAMAL
58	Magnetic Stirrer with Hot Plate	Stirring Capacity: 2 Ltr. Heating Capacity-300 Watts	SPINOT	01	PIRAMAL
59	Magnetic Stirrer with Hot Plate	Temp: 0°C to 310 °C Speed: 0 to 1500 Rpm	IKA	01	PIRAMAL
60	UV-Cabinet	Short UV-254 nm, Long UV-365nm & Visible Light	--	01	PIRAMAL
61	Refrigerator	200 Lit	ELECTROLUX	01	PIRAMAL
62	Refrigerator	200 Lit	LG	01	PIRAMAL
63	Refrigerator	200 Lit	GODREJ	01	PIRAMAL

64	Round Water Bath	Temp Range: 50 °C to 250 °C, Acc: +/-2 °C	COSLAB	01	PIRAMAL
DEPARTMENT OF BOTANY					
65	Compound Microscope	10 X to 45 X	Coslab	05	INSTITUTE
66	PH Meter	Acidic to Basic	Toshcon	02	INSTITUTE
67	Vaccum Pump	0.25 Gp light weight	Value	01	INSTITUTE
68	Oven	50 °C to 300 °C	Biotech India	01	INSTITUTE
69	Autoclave	0 to 30 psi-kg/cm ²	Biotech India	01	INSTITUTE
70	Rotary Microtome	0.25μ to 100μ	Coslab	01	INSTITUTE
71	Centrifuge machine	1000 to 5000 rpm	Remi	01	INSTITUTE
72	Digital weighing Balance	Max 120 g to min 0.001 g	Citizen	01	INSTITUTE
73	Dissecting Microscope	Full-size stereo zoom	Coslab	12	INSTITUTE
74	Water bath	30 °C to 110°C	Biotech India	02	INSTITUTE
75	Soil testing kit	For checking soil parameters	Prerana laboratory	01	INSTITUTE
76	Distillation unit	Glass, 2lit.		01	INSTITUTE
77	Spectrophotometer	To read the wave length 300 nm to 700 nm	Systronics	01	SPPU/QIP
78	Vertical Electrophoresis with power pack	15 x12 cm, Gel-12 walls	Genie	01	INSTITUTE
79	Horizontal Electrophoreus with power pack	12 x 8 cm Gel-12 walls	Genie	01	INSTITUTE
80	UV translumination	20 x 20 cm	Genie	01	INSTITUTE
81	Agarose gel Eelectro phorsis	15 x 12 cm Gel : 1 Walls	Genie	01	INSTITUTE
82	Autoclave	12 x 12 inch	Biotech India	01	INSTITUTE
83	Simple Microscope	KGs	Coslab	25	INSTITUTE
84	Boerner Divider Model	Divide Seed from physical impurity	Sunshine	01	INSTITUTE
85	Soil Type Divider Model 113	Divider of Soil Filters	--	01	INSTITUTE
86	Digital Moisture Meter	Weight 9.5 kg Range 8 % – 40%	Sunshine	01	INSTITUTE
87	Seed Herbarium	Model S-129	Sunshine	01	INSTITUTE
88	Soxlet Apparatus	300 watts, RB flask with condenser	Borosil	01	INSTITUTE
89	Ocutor	--	Coslab	01	INSTITUTE
90	Digital Colorimeter	EQ-650	Equip tronics	01	INSTITUTE
91	Spinwin	--	Spinix	02	INSTITUTE
92	Voltmeter	--	Henei	01	INSTITUTE
93	Cooling Centrifuge	5250 RPM	Remi	01	INSTITUTE
94	Air Conditioner (A.C.)	0.3A, 5.5 Watts Cooling capacity 1700 Btu/hr	Duraed GE	01	INSTITUTE
95	Incubator	14x 14 14 cm	Biotech india	01	INSTITUTE
96	Cyclomixer	220-230 V, 50 Cycles/phase	Remi	01	INSTITUTE
97	Hygrometer	105mm, Scale Approx. 95	HUOER	01	INSTITUTE
98	Hygrometer	105mm, Scale Approx. 95		01	INSTITUTE

99	Eyepiece	Resolution 5X	Quosmo	01	INSTITUTE
100	Sickle	Curved Iron Blade		02	INSTITUTE
101	Auxanometer	Measuring plant growth		01	INSTITUTE
B.VOC.					
102	UV Spectrophotometer	Double Beam	Systronics	01	UGC
103	Flame photometer with compressor	Minimum Sample Volume :3.5 ml	Systronics	01	UGC
104	PH meter	Micro controlled	Systronics	01	UGC
105	Trans illuminator	6X-BK1-Led	Genetix	01	UGC
106	Seed herbarium	Size 48'x24	Sunshine	01	UGC
107	Wooden slide Cabinet	5000 slides	Sunshine	01	UGC
PIRAMAL					
108	Microscope (CK X315SF)	100X TO 400X	Olympus	01	PIRAMAL
109	Olympus microscope(A16X)	100X TO 1000X	Olympus	01	PIRAMAL
110	Labomed microscope digi 3	10X	Digi 3	01	PIRAMAL
111	Binocular Microscope	100X TO 1000X	Zeiss	01	PIRAMAL
112	Vortex	50 Hz	Remi	02	PIRAMAL
113	Vortex	50 Hz	Genie	01	PIRAMAL
114	Deep fridge Refrigerator	8°C to -22°C	Siemens	01	PIRAMAL
115	Power pack	50V TO 100 V	Unik Enterprises	01	PIRAMAL
116	Roto -Shaker	RPM : 10 - 100	--	01	PIRAMAL
117	Electronic Weighing Maching	1 g to 100 g	Essae	01	PIRAMAL
118	Refrigerator	0 to 8 °C	Electrolux	01	PIRAMAL
119	Refrigerator	Upto - 20 °C	Simmons	01	PIRAMAL
120	Laminar Air flow	HEPA filter and UV Light	Aleolus	02	PIRAMAL
121	Shaker	For blending and Agitation	Thermo scientific	01	PIRAMAL
122	Electronic Weighing Machine	1 gm to 10 kg	ESSAE	01	PIRAMAL
123	Binocular Microscope	10 X to 100 X	Coslab	01	PIRAMAL
124	Phase contrast Microscope	10 X to 65 X	Nikon	01	PIRAMAL
125	Roto shaker	Platform capacity 4.500kg	Remi	01	PIRAMAL
126	Micropipettes	1µl to 1000µl	Thermo and Eppendorf	03	PIRAMAL
127	PCR machine	DNA Amplification	MJ Research	01	PIRAMAL
128	Rota Vapour	Water bath range: upto 100 °C	Equitron Roteva	01	PIRAMAL
129	Cyclomixer	Speed: Upto 1500 rpm	Remi	01	PIRAMAL
130	Rotary Evaporator	1100 watts 230 AC volts	Equitron	01	PIRAMAL

131	Power pack universal power supply	Max power 650V ,Frequency 50/60 Hz	Bio -RAD	01	PIRAMAL
132	Alpha Unit block Assembly for DNA Engine Systems	100-240V. Frequency 50-60 Hz	MJ Research	01	PIRAMAL
DEPARTMENT OF PHYSICS					
133	Ultrasonic cleaner	ATS-2	Athena	01	SPPU/QIP/2018-19/01
134	Digital Picoammeter	DPM-111-C2	Roorkee	01	SPPU/QIP/2018-19/02
135	Keithley Multimeter	6 ½ digit DMM Set to 220V 2100/220	Kethley	01	SPPU/QIP/2018-19/03
136	TEP Unit	Pellet testing at 300 °C	Borade	01	SPPU/QIP/2018-19/04
137	CRO	Dual Channel/Dual Trace 30 MHz	Aplab	1	INSTITUTE
138	CRO	Dual Channel/Dual Trace 30 MHz	Scientch	05	INSTITUTE
139	He-Ne Laser	7000Volts 2Milliwatt max.o/p 220v Ac 50Hz	Besto	01	INSTITUTE
140	He-Ne Laser	7000Volts 2Milliwatt max.o/p	coslab	03	INSTITUTE
141	Hall Effect	Charge to mass ratio	SES	01	INSTITUTE
142	G.M. Counter	Digital ZT-784	Ridda India	01	INSTITUTE
143	Measurement of Susceptibility of Solids by Gouy's method	GMX-02 Complete in all respect	SES	01	INSTITUTE
144	Zeeman Effect	ZEX-01 including 14" monitor and CCD Camera	SES	01	INSTITUTE
145	Fabry-parot Etalon	--	SES	01	INSTITUTE
146	Study of Dielectric Constant & Curie Temp. of Ferroelectric cera.	DEC-01 complete in all respect	SES	01	INSTITUTE
147	Potentiostat	Advanced with Customized Software	KLY +1.2	01	INSTITUTE
148	DC Power supply	0-30V 2Amp	Sciencetech	05	INSTITUTE
149	Ultra sonic Interferometer	2MHz	BESTO	01	INSTITUTE
150	Dual Power Supply	0-30V 2Amp	Sciencetech	04	INSTITUTE
151	Muffle furnace	Size-25x13x13 cm Standard Working Temperature-1600 ^c	Bio Tech	01	MRP
152	Magnestic strirror with hot plate	Stirring Capacity-2 Ltr. Heating Capacity-300 Watts,	Coslab	01	MRP

153	Fume hood stainless steel	120 x 60 x60 cm	Reschol	01	MRP
154	Hydrothermal Unit	Temp Range: 0- 350 °C	Custom	01	MRP
155	Function Generator	3MHz with 40MHz freq. counter	Sciencetech	05	INSTITUTE
156	Function Generator	3MHz with 40MHz freq. counter	Aplab	01	INSTITUTE
157	Gas sensing unit	Heating element for substrate under sensing	Custom	01	MRP
158	Compressor	50 lit. 2HP	Markpower stools	01	MRP
159	Michelson Interferometer	HL-517 Dia.17mm,Pitch 1 mm,length 200mm	SES	01	INSTITUTE
160	e/m Experiment	EMX-01	SES	01	INSTITUTE
161	Four Probe Set up	Research model DFP-RM-200	Modern	01	INSTITUTE
162	Milikin Oil drop experiment	MOD-01 Complete in all respect	SES	02	INSTITUTE
163	Full Setup for Stefan Const.	Black Colored Box	Prowiz System	01	INSTITUTE
164	Absorption Spectrum of Iodine vapour	Glass tube of 1 m	Prowiz System	01	INSTITUTE
165	Study of Photovoltaic Chr. Of Solar cell	Variation of intensity	Prowiz System	01	INSTITUTE
166	Solar power photovoltaic system	VOC is 5 volt	Prowiz System	01	INSTITUTE
167	Combination of solar photovoltaic panels	02 Panel	Prowiz System	01	INSTITUTE
168	Solar collector	Efficiency versus/I,ETC Type	Prowiz System	01	INSTITUTE
169	Coefficient flat plate collector	FPC	Prowiz System	01	INSTITUTE
170	Solar Cooker	Box Type	Prowiz System	01	INSTITUTE
171	Sun Meter	DSM02	PV energy expert	03	INSTITUTE
172	Spray Pyrolysis Unit	Moving gun along x-axis,gun-substrate distance adjustment	Custom	01	MRP
173	Frank Hertz Experiment	FH-3001	SES	01	INSTITUTE
174	Screen Printing set-up	Adjustable mesh thickness	Custom	02	MRP
B.VOC.					
175	Hydraulic Press.	Pressure (10 ton)	Borade Embedded	01	UGC
176	Hot Air Oven	50 °C to 300 °C	MI	01	UGC

177	CRO	Dual Channel/Dual Trace 30 MHz	Sciencetech	04	UGC
178	Function Generator	3MHz with 40MHz freq. counter	Sciencetech	04	UGC
179	Dual Power Supply	0-30 V , 2 amp	Sciencetech	04	UGC
180	Solar Power Lab	LCD Display for Voltage & Current meas.	Nvis	01	UGC
181	Digital Multimeter	4000 count large LCD Display	Sciencetech	04	UGC
182	Water Distillation Plant	Capacity: 4 Ltr	Mod. Science	01	UGC
PIRAMAL					
183	Digital Balance	Upto 4 Digit	Denver	01	PIRAMAL
184	Refrigerator	430 Lit.	LG	01	PIRAMAL
185	Micro Oven	230V, 50Hz	Sanyo	01	PIRAMAL
186	Water bath	30 °C to 110 °C	Fisher Scientific	01	PIRAMAL
187	IR Lamp	230V	Philips	01	PIRAMAL
188	Mag. Stirrer With Hot plate	Stirring Capacity: 2 Ltr. Heating Capacity: 300 Watt	Tarsons spinot & MC02	01	PIRAMAL
189	Vortex Mixer(Shaker)	For blending and Agitation	Pro scientific	02	PIRAMAL
190	Vortex Mixer(Shaker)	For blending and Agitation	Scientific Industries	02	PIRAMAL
191	Digital Water bath	Heating Cap.: 30 °C to 110 °C	Scientific Sale Syndicate	01	PIRAMAL
192	Water bath	Heating Cap.:30 °C to 110 °C	NUVE(Kabul)	02	PIRAMAL
193	Centrifuge Machine	--	Daihan Scientific Co.	01	PIRAMAL
194	Thermo Mixer	--	Heidolph	03	PIRAMAL
DEPARTMENT OF ELECTRONICS					
195	Solar Simulator	Halogen lamp, filters, serial- parallel combination	N-vis	01	MRP-(UGC)
196	Spray Pyrolysis System	Moving gun along x-axis, gun-substrate distance adjustment	Custom-Made	01	MRP-(BCUD)
197	Automated SILAR Deposition System	Adjustable substrate holder - holding 1 to 5 substrates at a time, Fully computer controlled system.	Indigenously Developed in the Department	01	MRP-(BCUD)
198	Screen Printing	Adjustable mesh thickness	Custom-Made	01	MRP-(BCUD)
199	Gas Sensing Setup	Heating element for substrate under sensing	Custom-Made	01	MRP-(BCUD)
200	Water Distillation Plant	Five Liters per Hour	MI Instruments	01	MRP-(BCUD)

201	Digital Balance	0.1-180gm	Contech	01	INSTITUTE
202	Function Generator	3 MHz	Besto	03	INSTITUTE
203	Function Generator	3MHz	Sciencetech	02	INSTITUTE
204	CRO	Dual Channel Dual trace	Aplab	02	INSTITUTE
205	CRO	Dual Channel Dual trace	Sciencetech	02	INSTITUTE
206	Optical Fiber Communication Training kit	More than 10 Experiments can be performed	Sciencetech	01	INSTITUTE

DEPARTMENT OF ZOOLOGY

207	Microscope Binocular	10 X to 100 X	Coslab	01	INSTITUTE
208	Dissecting Microscope	Full-size stereo zoom	Coslab	10	INSTITUTE
209	Junior Medical Microscope With Movable Confessors	KGs	Coslab	15	INSTITUTE

DMLT

210	Microscope	10X to 100X	Labomed	01	INSTITUTE
211	Centrifuge	RPM: 3000	Remi	01	INSTITUTE
212	Oven	Temp Range: 50°C to 300°C	I-Therm	01	INSTITUTE
213	Incubator	14X14X14 inch	I-Therm	01	INSTITUTE

PIRAMAL

214	Thermo Centrifuge		Heraeus	01	PIRAMAL
215	Oven		Heraeus	01	PIRAMAL
216	Laminar Air Flow	HEPA filter and UV Light	Klenzaid	01	PIRAMAL
217	Incubator	--	Lawrence & Mayo	01	PIRAMAL
218	Refrigerator	--	Heraeus	01	PIRAMAL

GEOGRAPHY

219	Plane Table Set	Surveying	Usew India	01	INSTITUTE
220	Ordinary Rain gauge set	Measure Rain	Usew India	01	INSTITUTE
221	Wind Vane set	Calculate wind Speed	Usew India	01	INSTITUTE
222	Global Positioning system	Surveying	Garmin	01	INSTITUTE
223	Theodolite	Surveying	Usew India	01	INSTITUTE
224	Dumpy level	Surveying	Usew India	01	INSTITUTE

225	Plane Table	Surveying	Usew India	02	INSTITUTE
226	Prismatic compass	Surveying	Usew India	02	INSTITUTE
227	Weather station	These machines are Automatic, in which the daily atmospheric conditions, changes are reported. For example: Detailed information about factors like temperature, humidity, reproduction, air speed, wind direction, air pressure, etc. is sent to the farmers, village panchayats and students and other villagers by sending information about whatsapp group. Considering the emergence of emergency, the prediction of this machine can be avoided to prevent the loss of farmers.	Davis	01	INSTITUTE
228	Camera	Digital Camera, To Capture Google Snapshot	Sony	01	MRP
229	Body Mass Index	Karda Body Scan Instument	Omraon	01	MRP



SNJB (Jain Gurukul's)
K.K.H. Abad Arts, S.M.G. Lodha Commerce & S.P.H. Jain Science College
Neminagar, Chandwad-423101, Dist.-Nashik, Maharashtra

(Affiliated to Savitribai Phule Pune University) Id. No.PU/NS/AC/015/1970

(02556) Off. 252125 Res.252126 Tel. Fax:02556-252125

• P. O. Box No.: 6 • E-mail : alccchandwad@yahoo.co.in

• Website : www.acschandwadcollege.com

DST-FIST Funded (2018-19)

UGC-NSQF Courses (B.Voc. & CC)

Best College Award by Savitribai Phule Pune University (2015-16)

Establishment
27/11/1928

Teaching- Learning Facilities



Spray Pyrolysis Deposition System

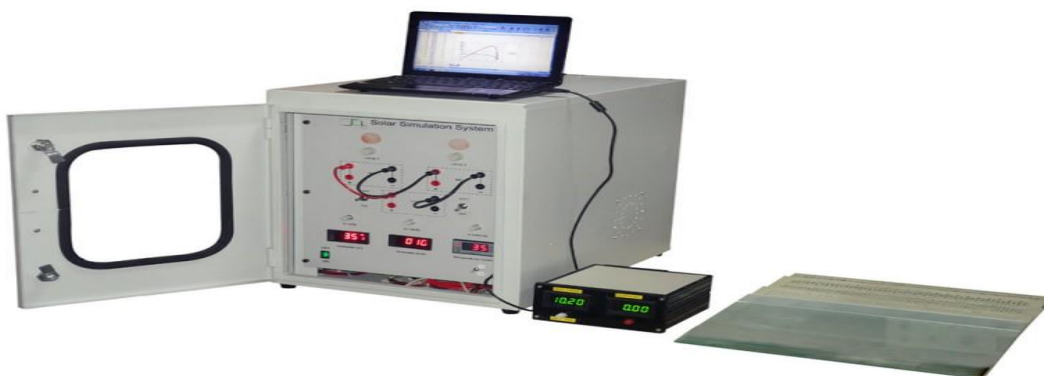

Solar Simulation System



Successive Ionic layer Adsorption Reaction (SILAR) system

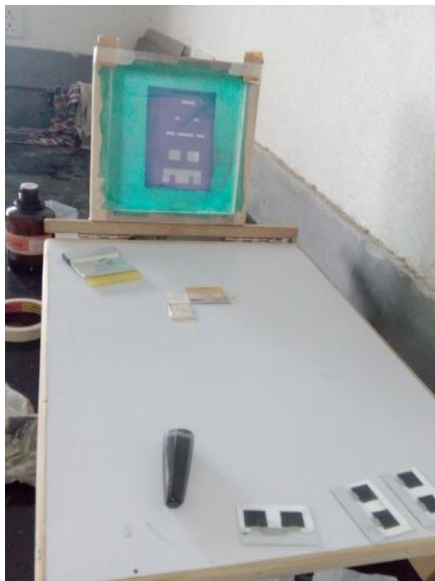

Screenprinting System



Sensing Probes



Gas Sensing setup



Central Instrumentation facility



Central Instrumentation facility laboratory



FTIR



UV Visible Spectrophotometer



Spectrophotometer



Suction Pump

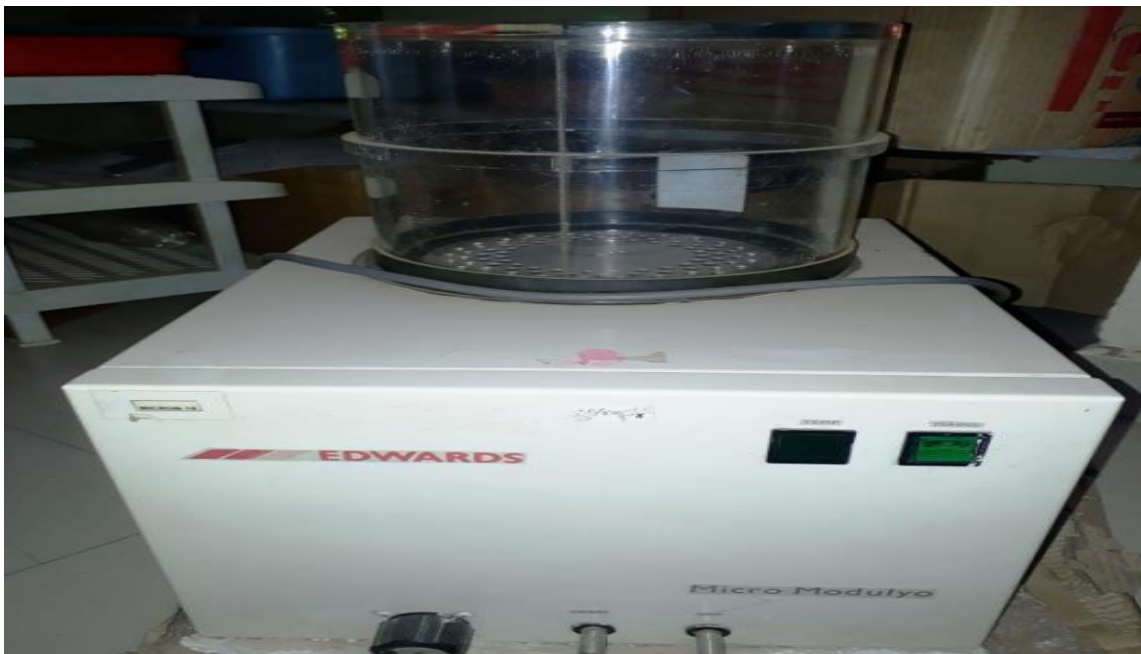

Fume hood of stainless steel

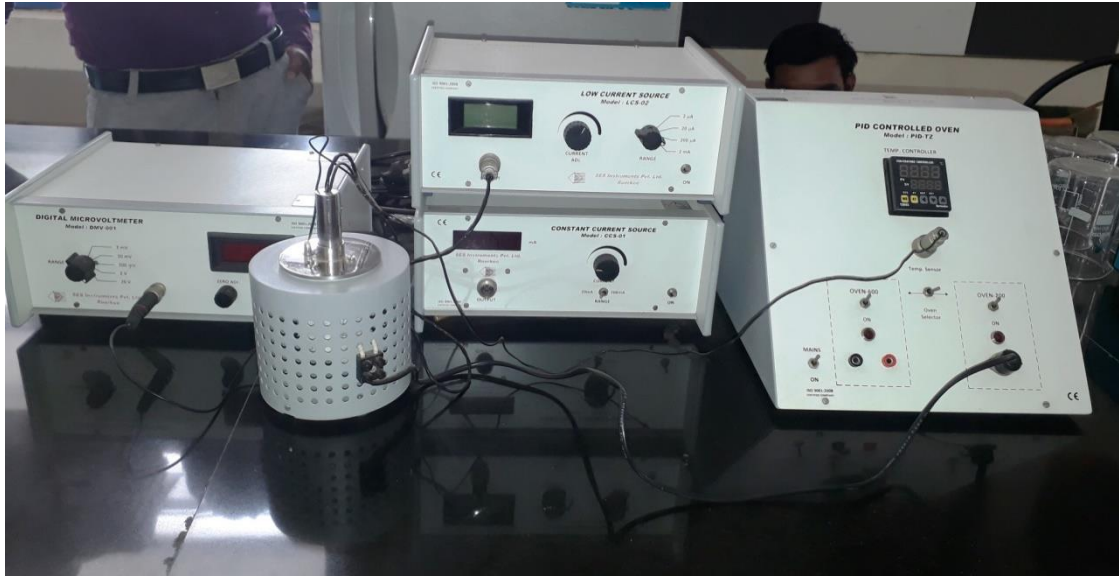

Resistivity of semiconductor by four probe method



Hall Effect Experiment



G. M. Counter Digital



Millikans Oil Drop Method



Apparatus for Measuring Susceptibility of Solids



Electron Spin Resonance Spectrometer



Zeeman Effect



Micro Oven



Digital water Bath



Centrifuge Machine

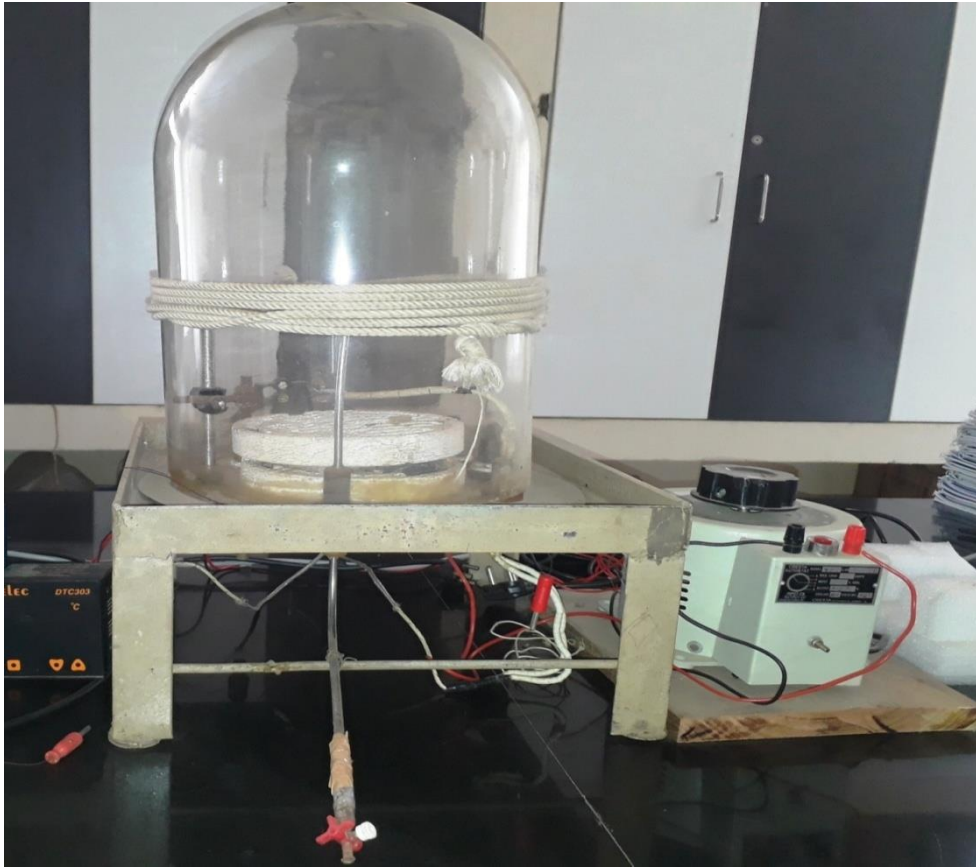

Gas Sensing Unit



Muffle Furnace



Hydrothermal Unit



Potentiostat (Klyte 1.2) with customized software



Ultrasonic Interferometer Frequency 2MHz



Ultrasonic Cleaner (Sonicator)



Digital Picoammeter



Digital Multimeter



TEP UNIT



Spray Pyrolysis unit

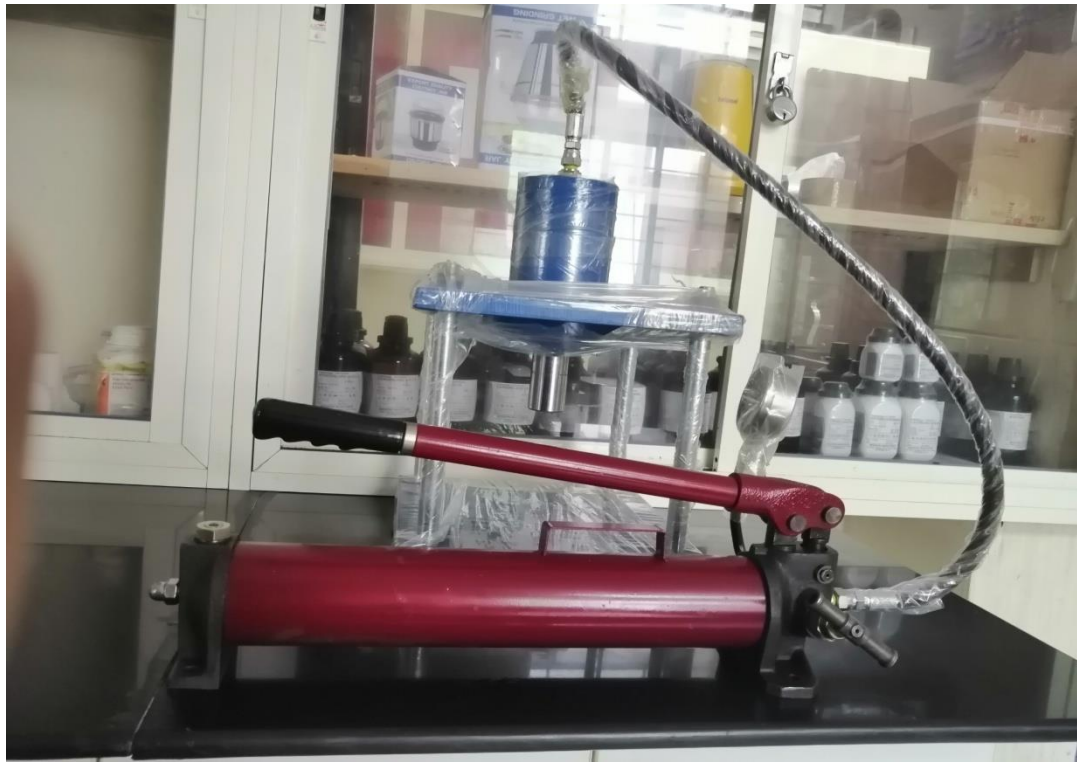

Hydraulic Press 10ton.



Hot Air Oven



Departmental Computer lab.

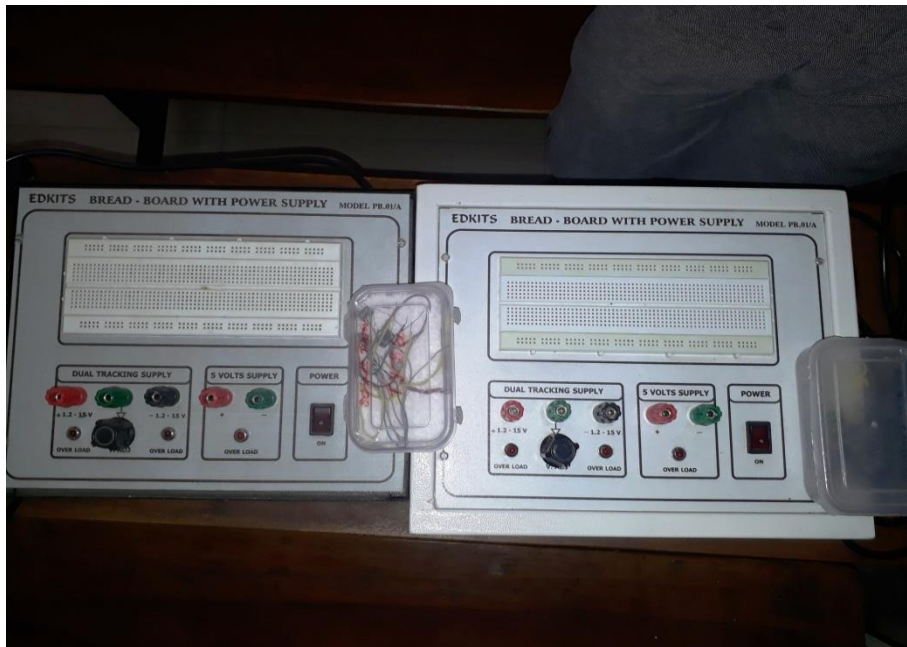

Bread board with power supply



Compound pendulum



CRO



Function generator



Inertia DNCB2373



Intermediate Spectrometer

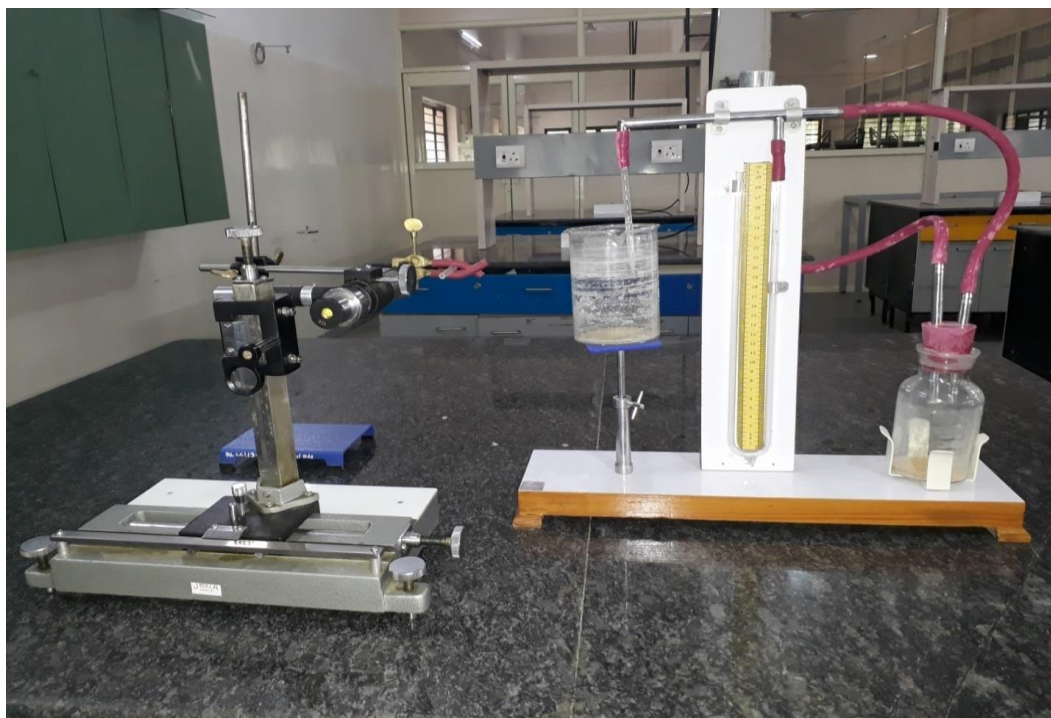

Jagers Surface Tension

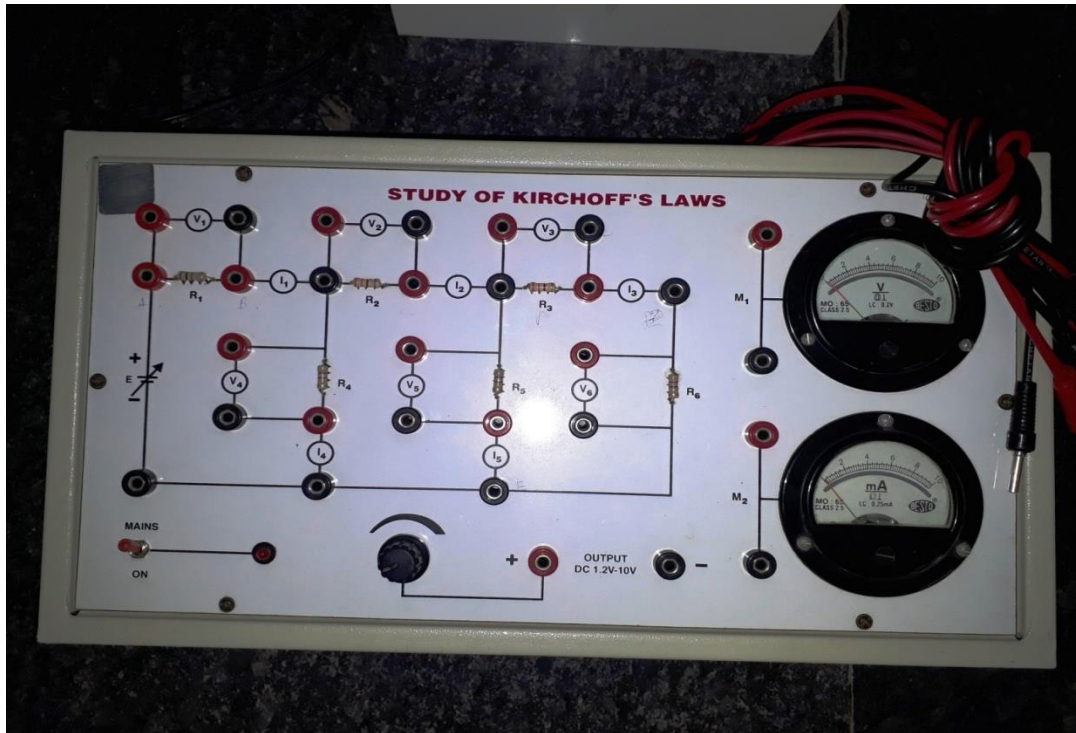

Kirchoffs Law

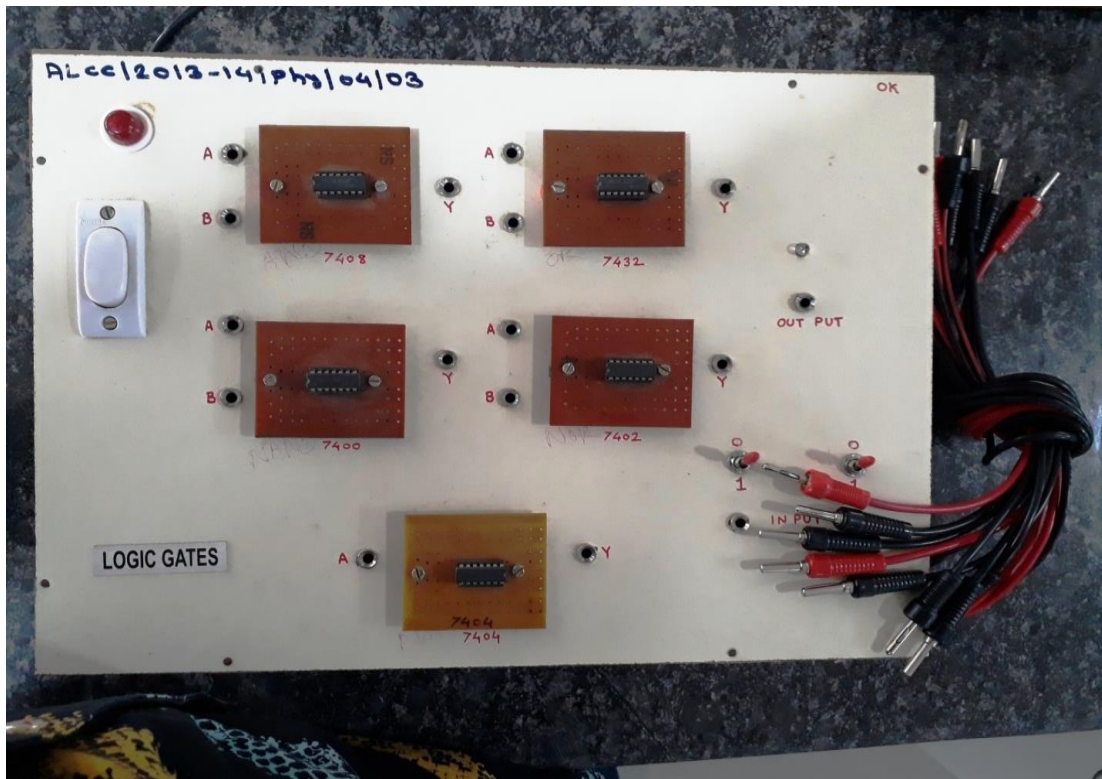

Logic Gates



Newtons Ring with Mocriscope

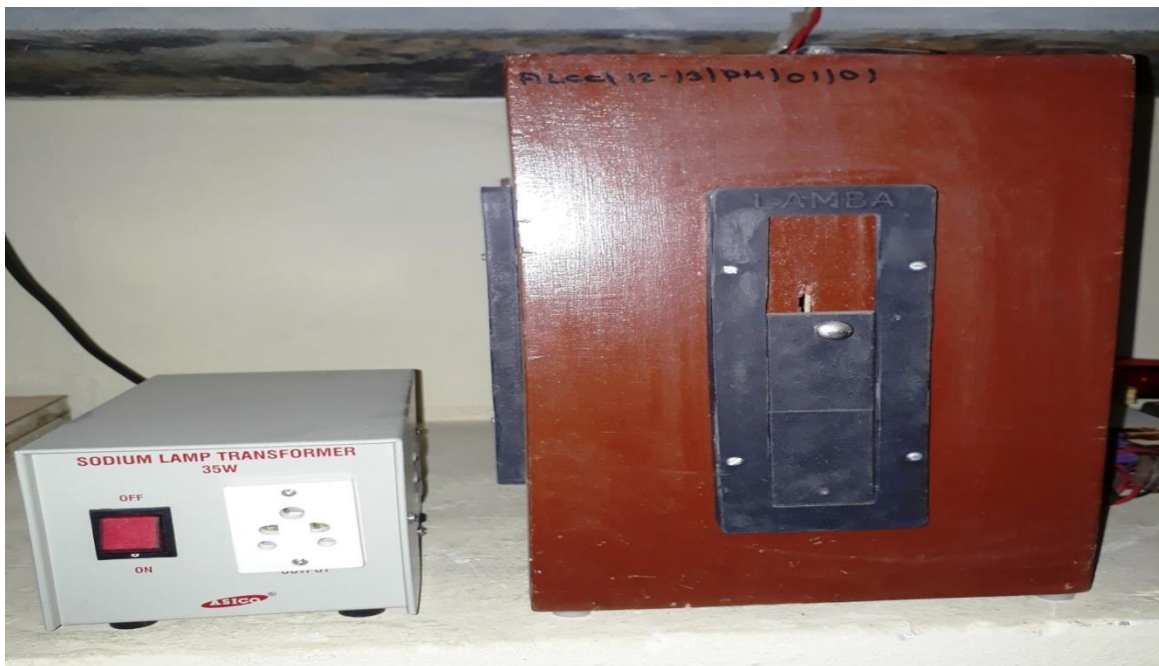

Sodium Vapour Lamp with Transformer and Wooden Box

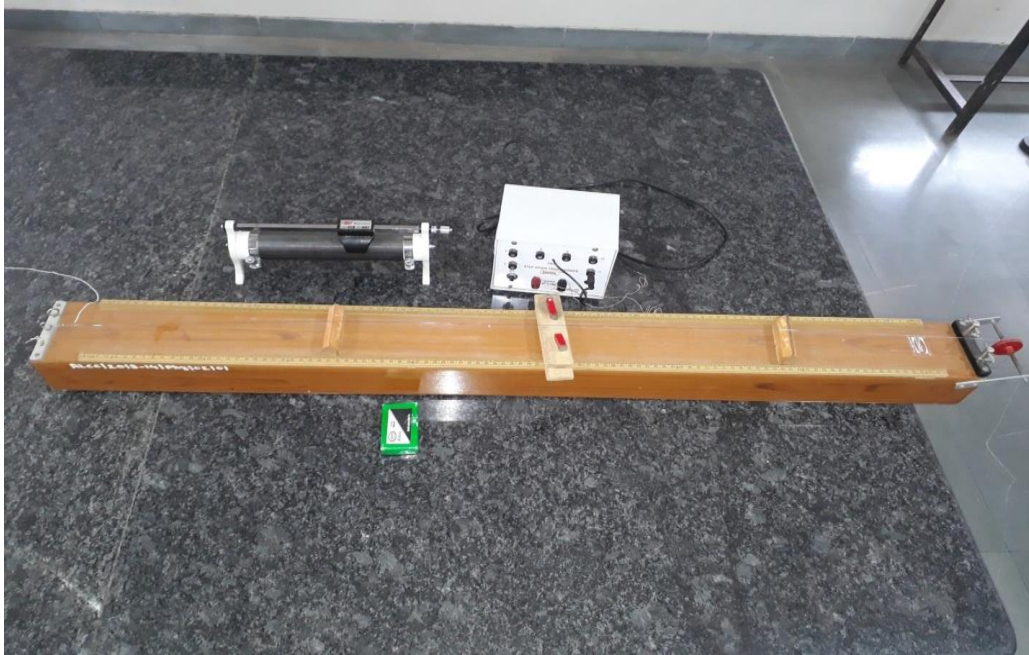

Sonometer



Spectrometer Besto



Flat Spiral Springs, Weights box and Stopclocks



Travelling Microscope

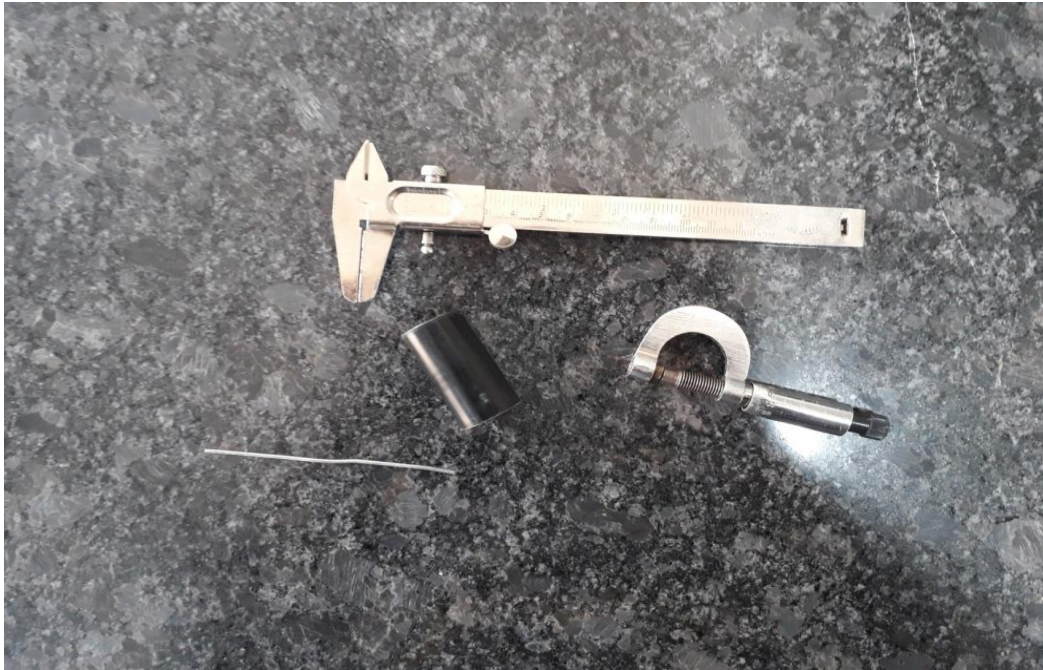

Vernier Calliper and Micrometer Screw Gauge



Stepdown Transformer



Magaetic Strirrer with hot plateFume



Forbes apparatus



Thermal Conductivity of Rubber Tubing



Platinum resistance thermometer



E/M by Thomsons Method



Polarimeter Bi-Quartz

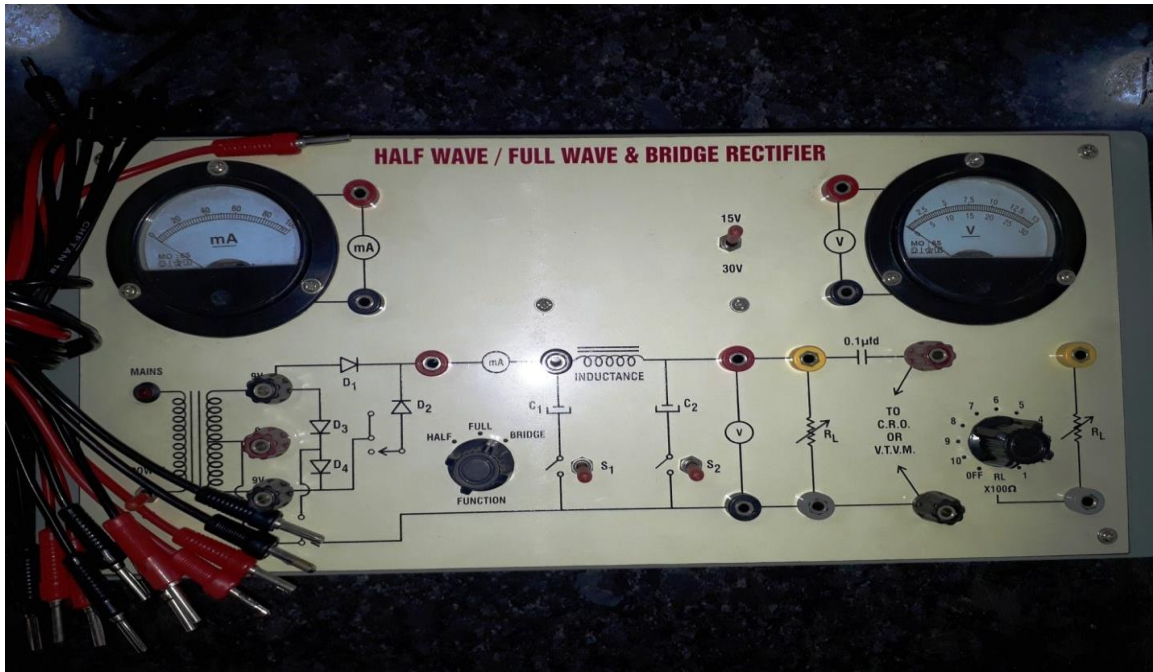

Semiconductor diode as half wave and full wave rectifier unit



UJT Characteristics Apparatus

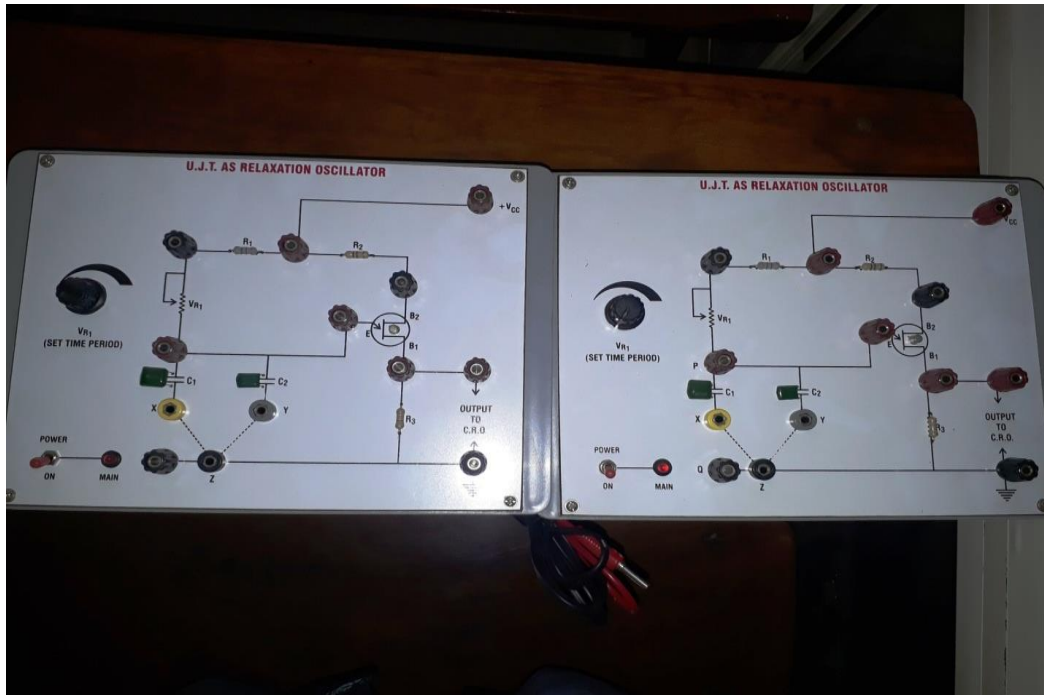

UJT Relaxation Oscillator

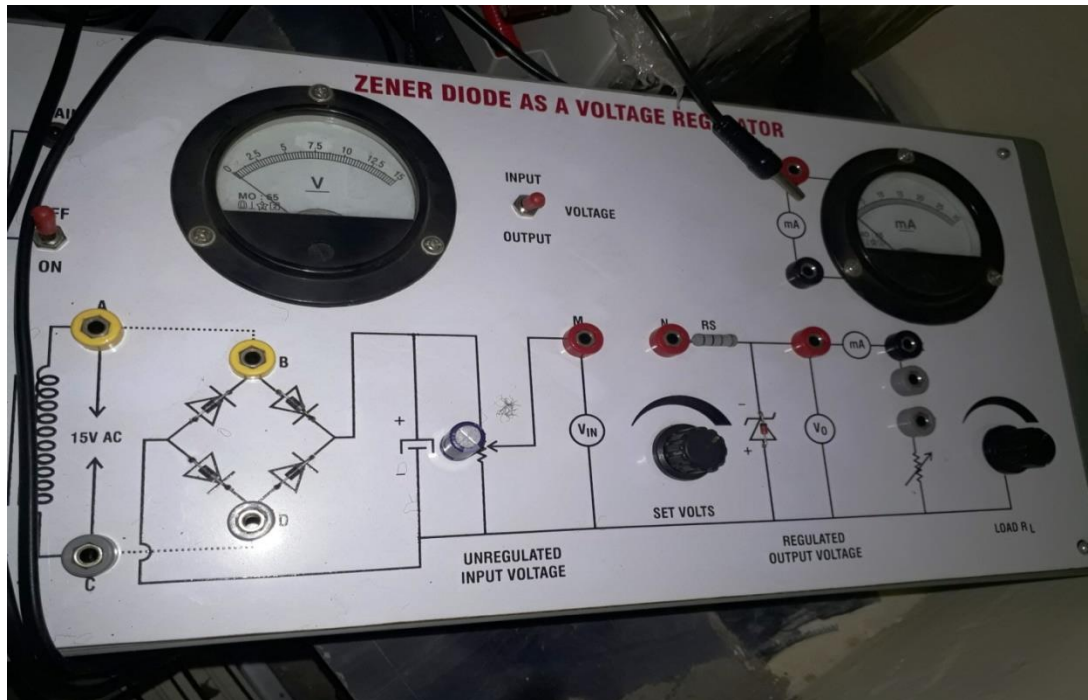

Zener Diode as A Voltage Regulator



Phase Shift Oscillator

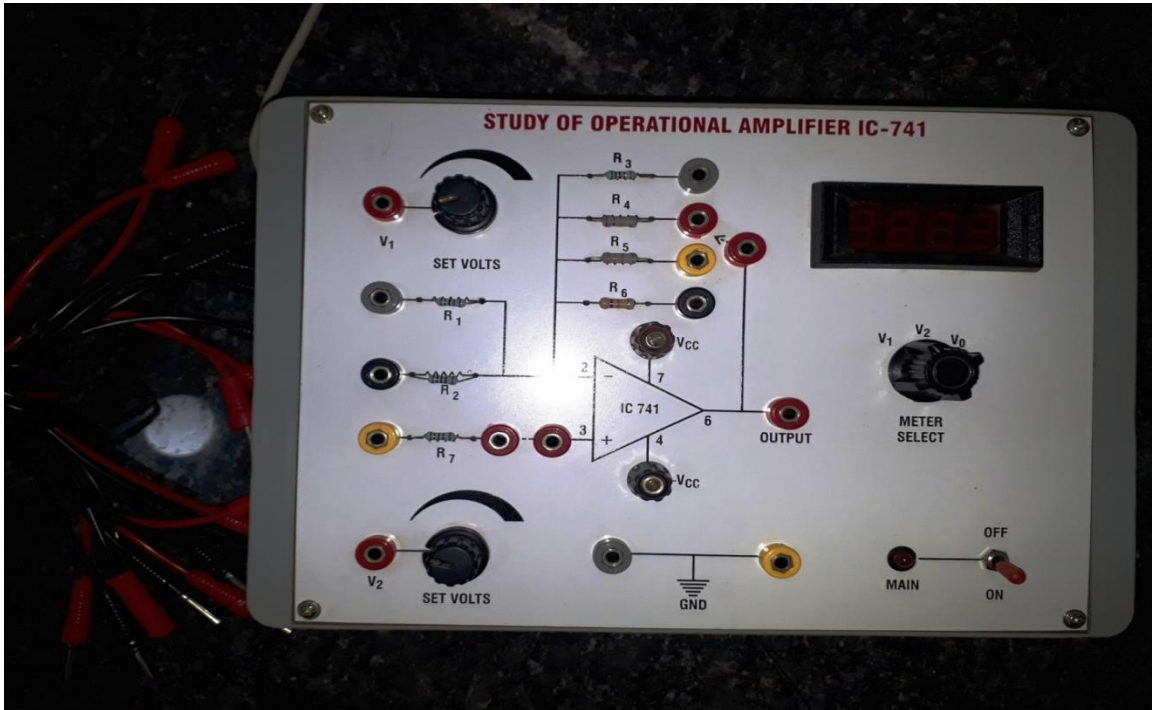

Op –AMP as inverting and non-inverting amplifier

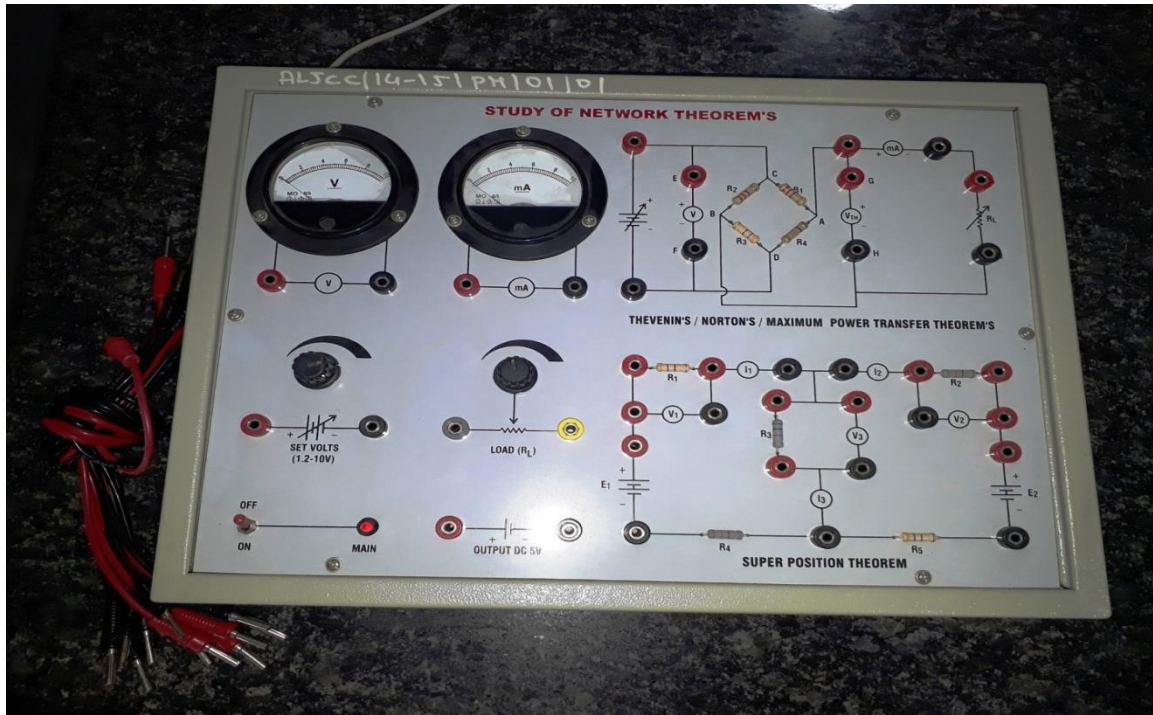

Varification of Network Theorem

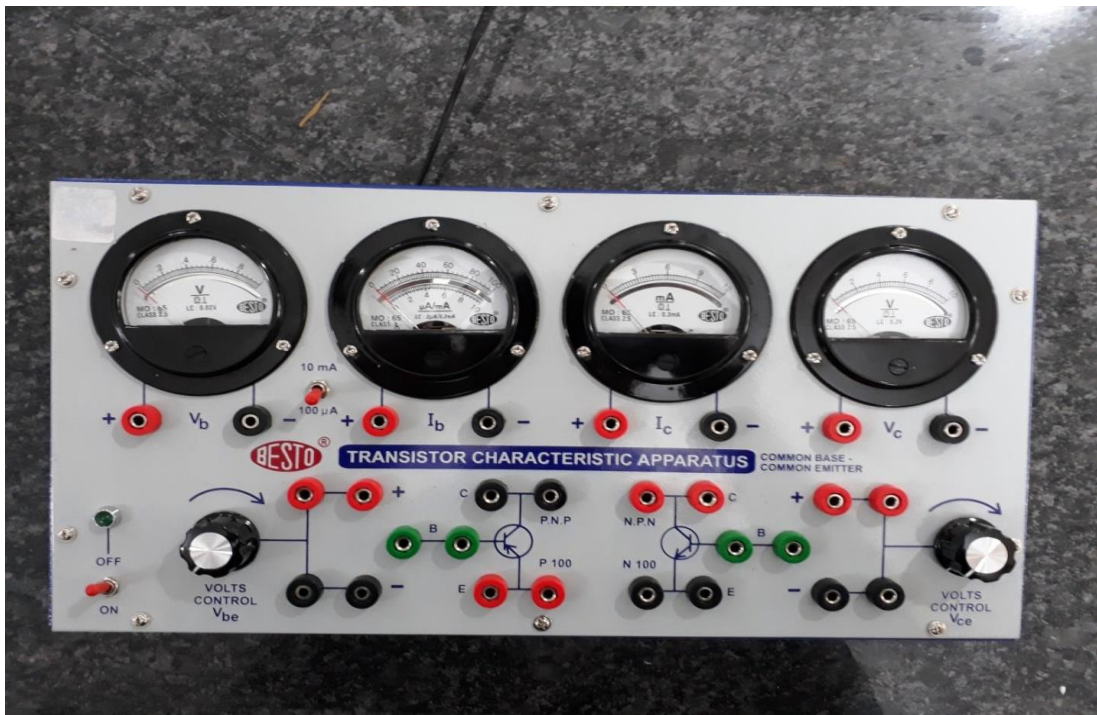

Transistor Characteristics Apparatus



Electron Spin Resonance Spectrometer



Frank Hertz Experiment

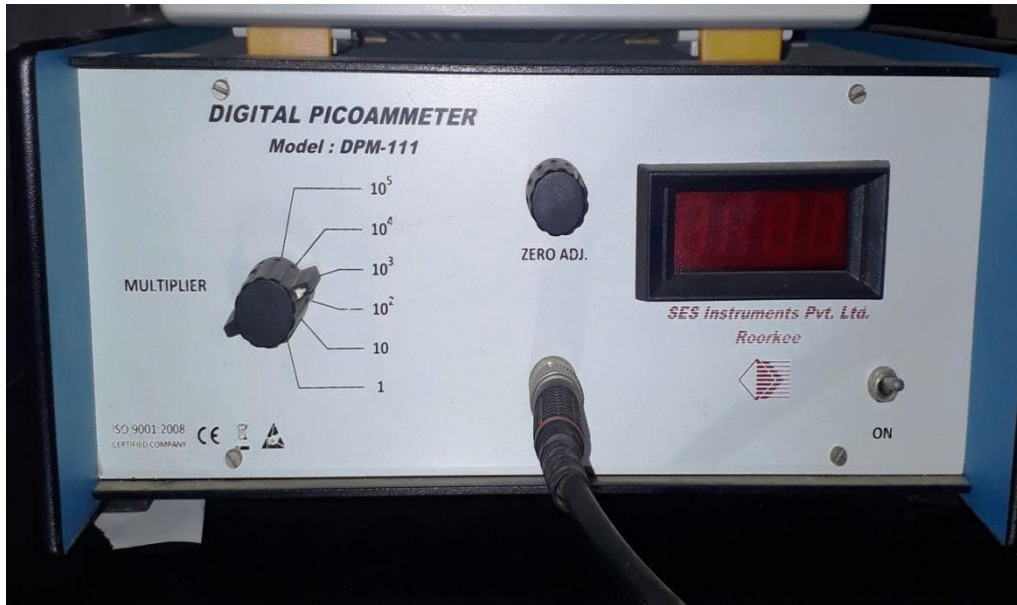

Digital Picometer

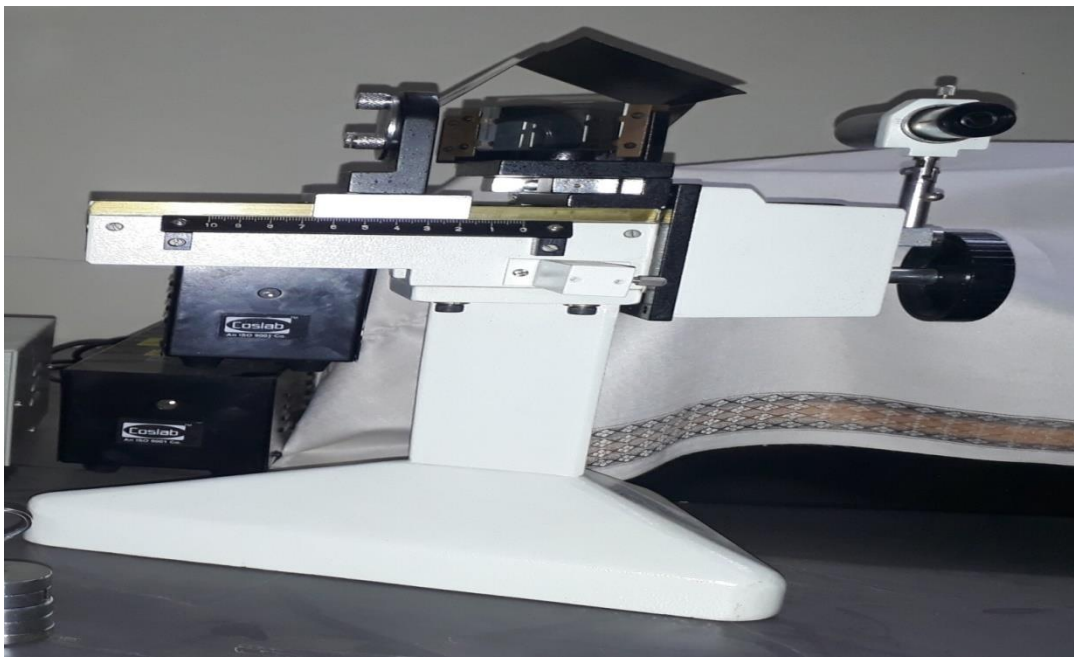

Michelson Interferometer



Study of dielectric constant

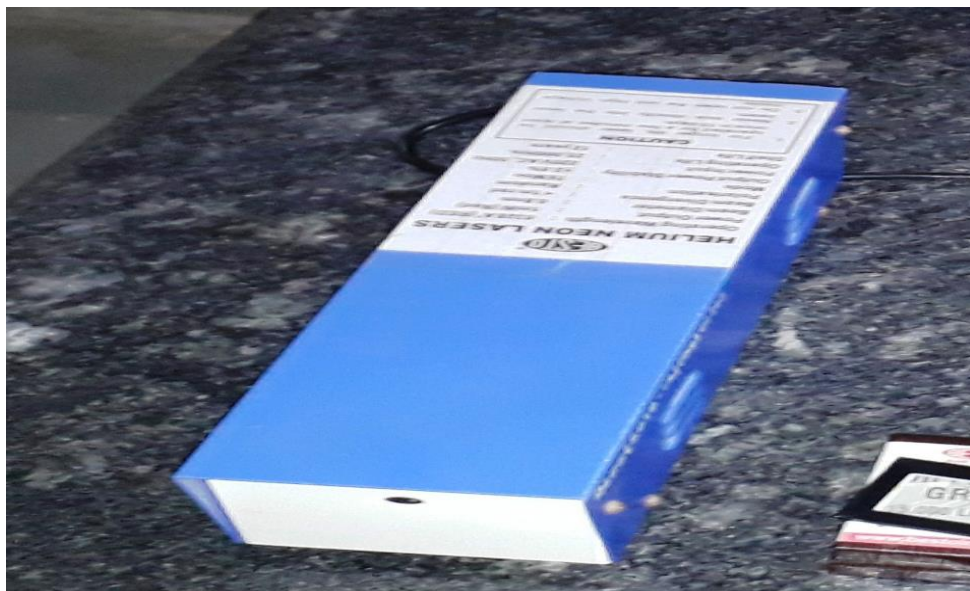

He-Ne Laser

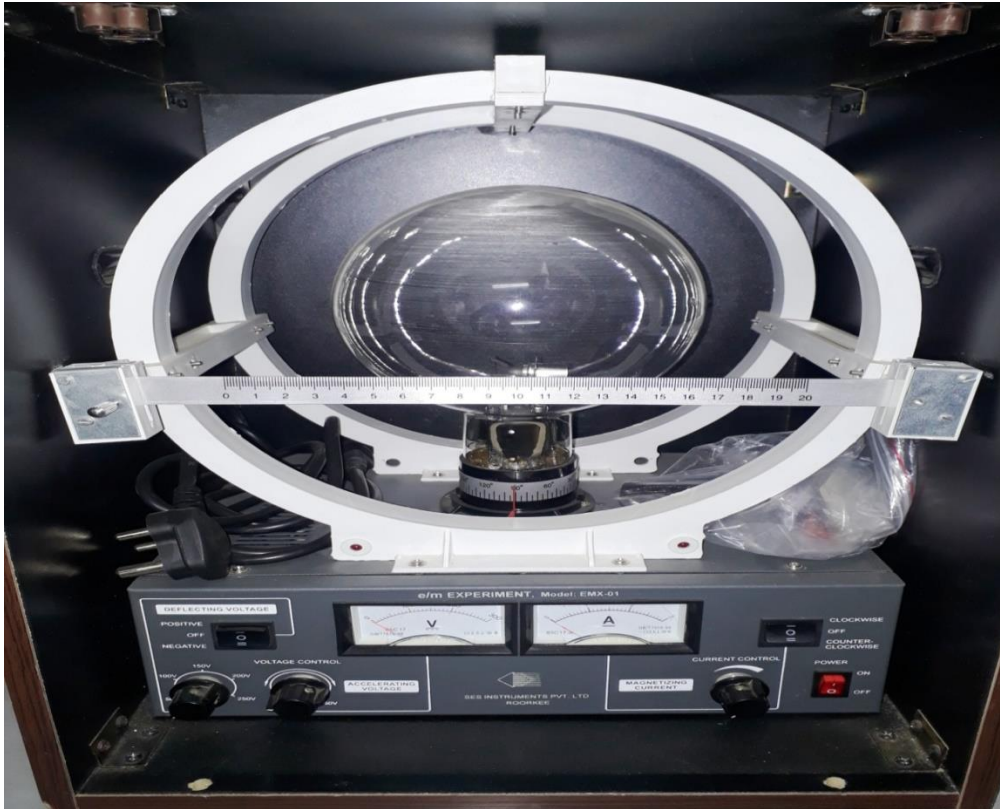

e/m Experiment

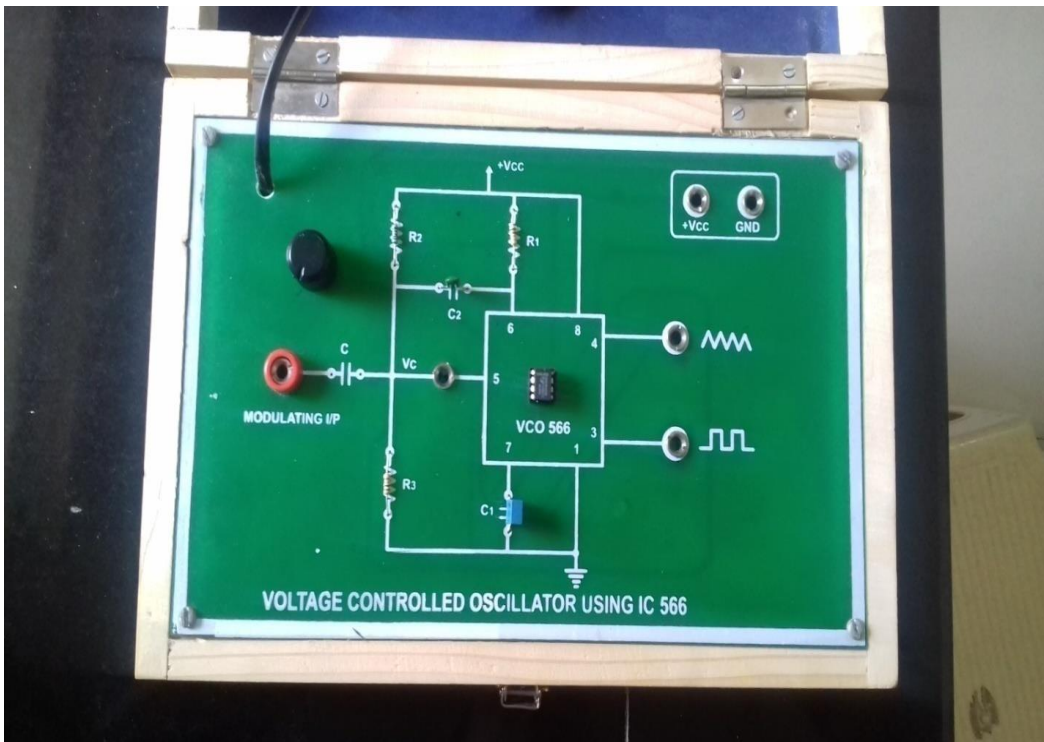

Study of VCO

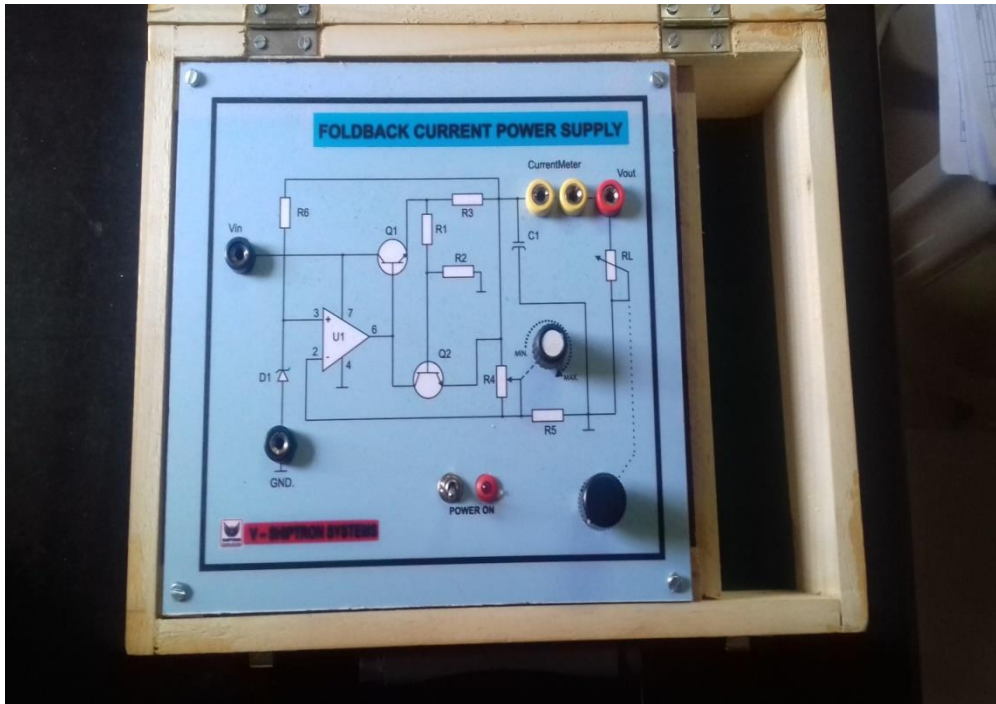

Foldback Power Supply

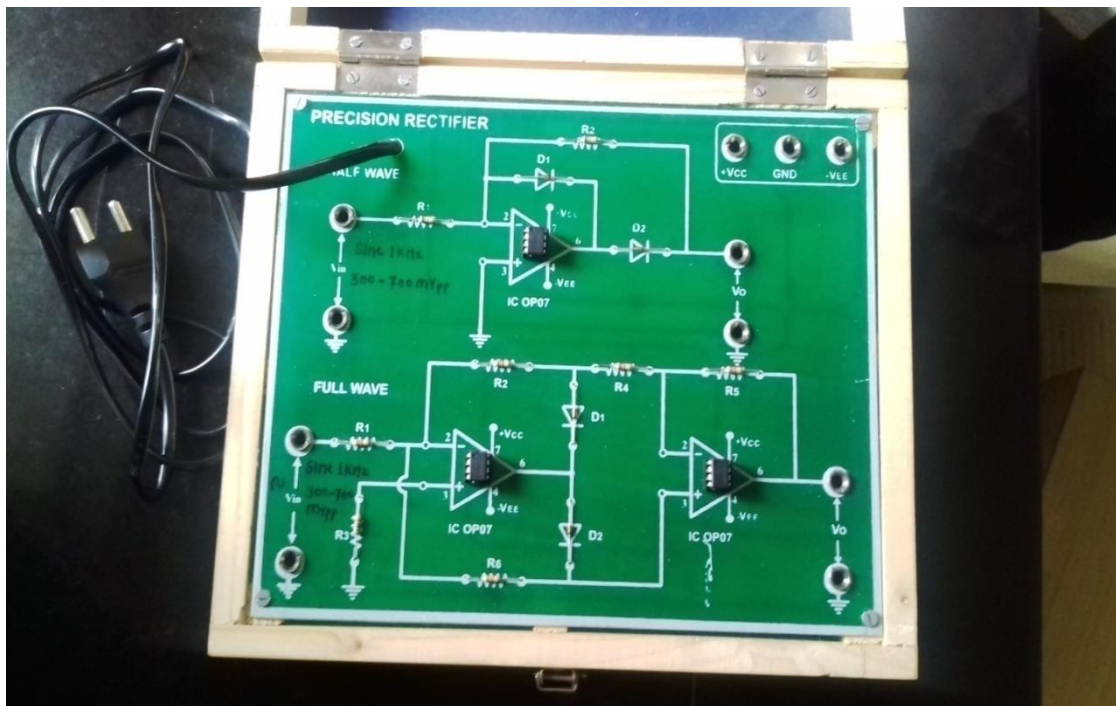

Precision Rectifier

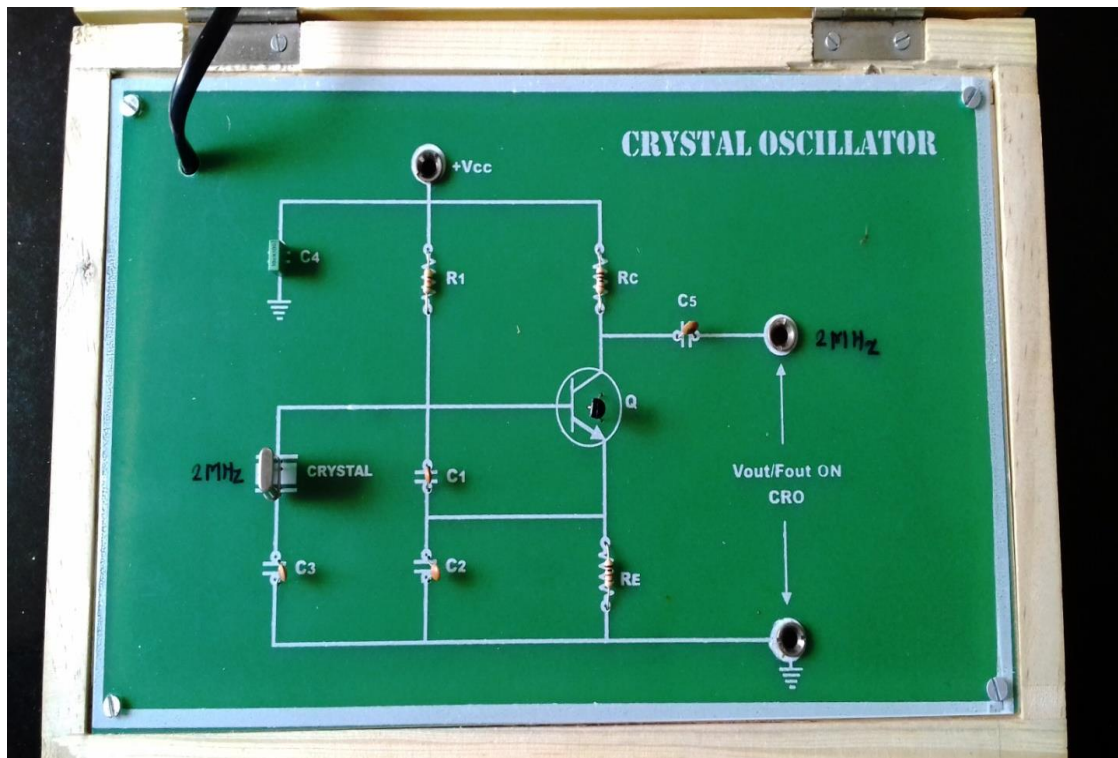

Crystal Oscillator

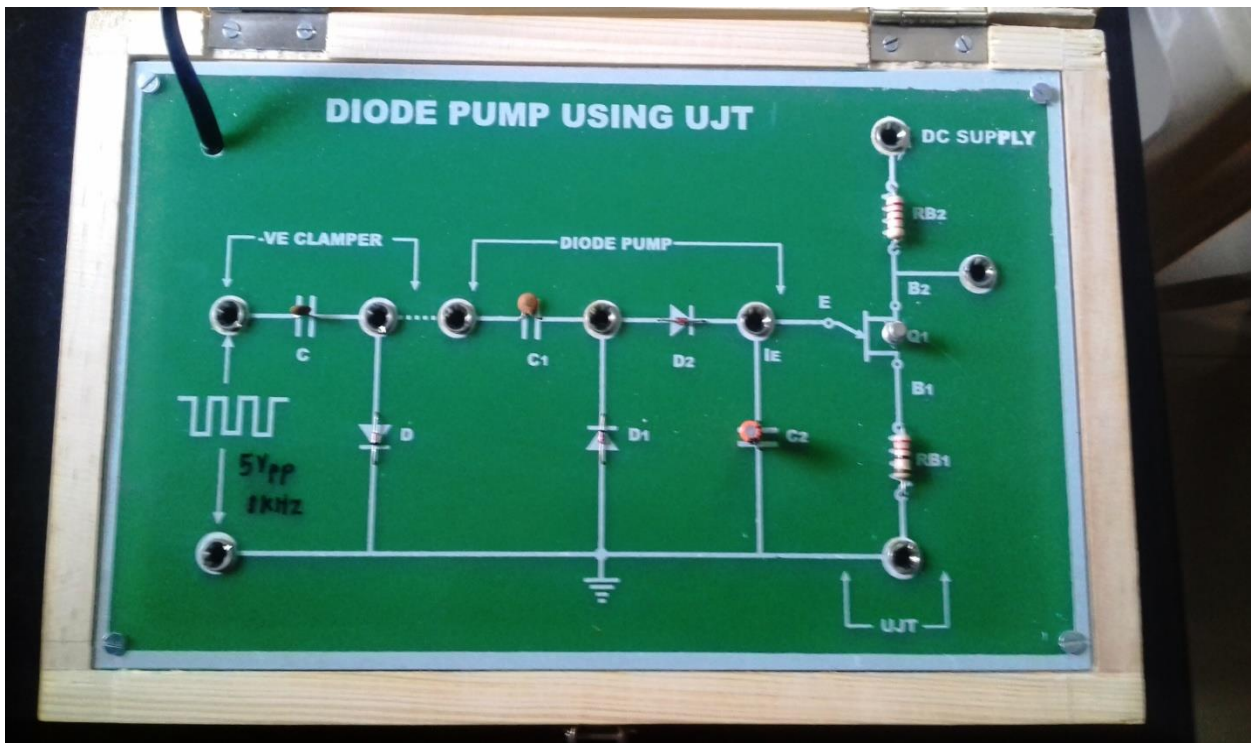

Diode Pump Using UJT

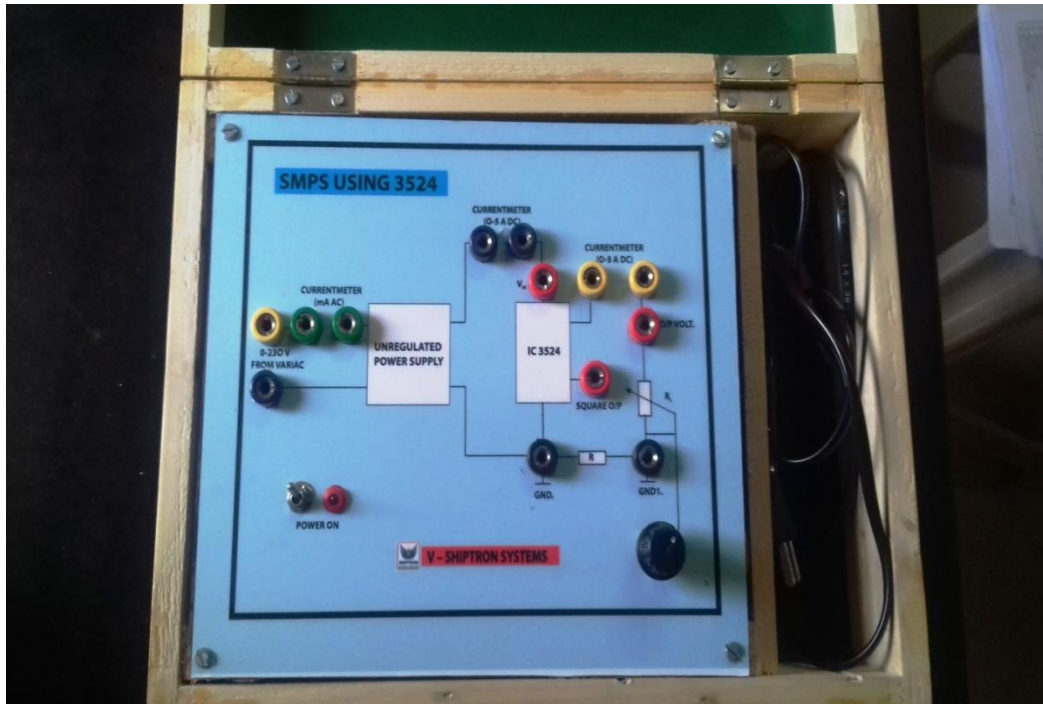

SMPS

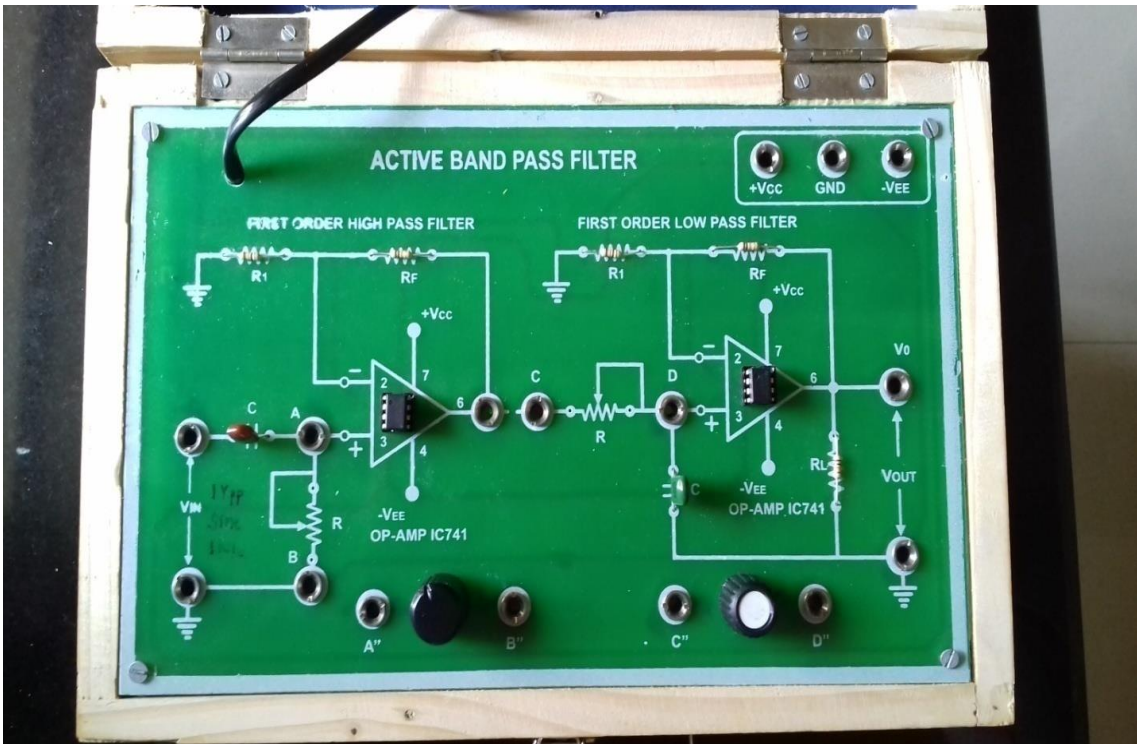

Active Band Pass Filter



Function Generator

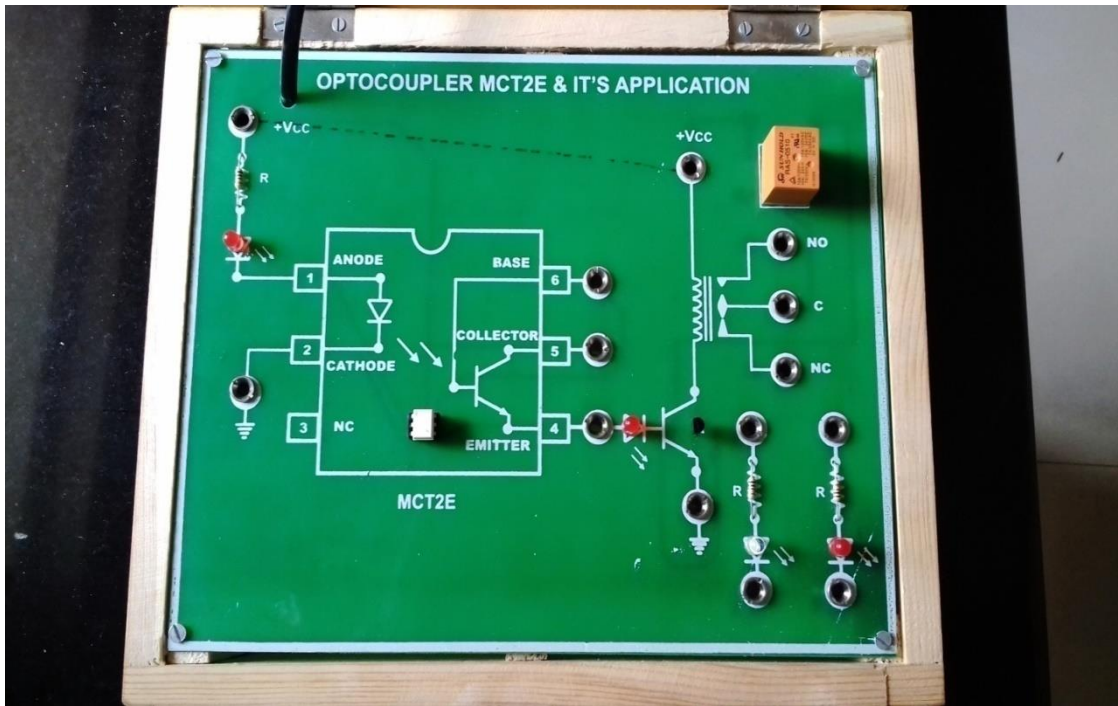

Optocoupler

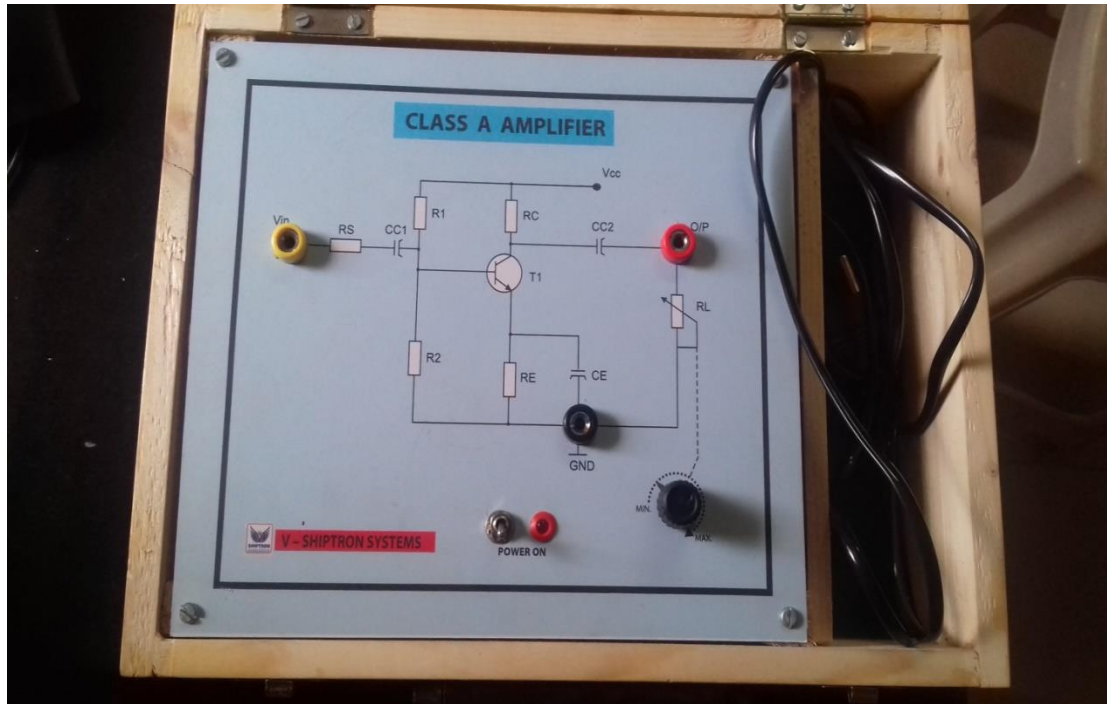

Class A Amplifier

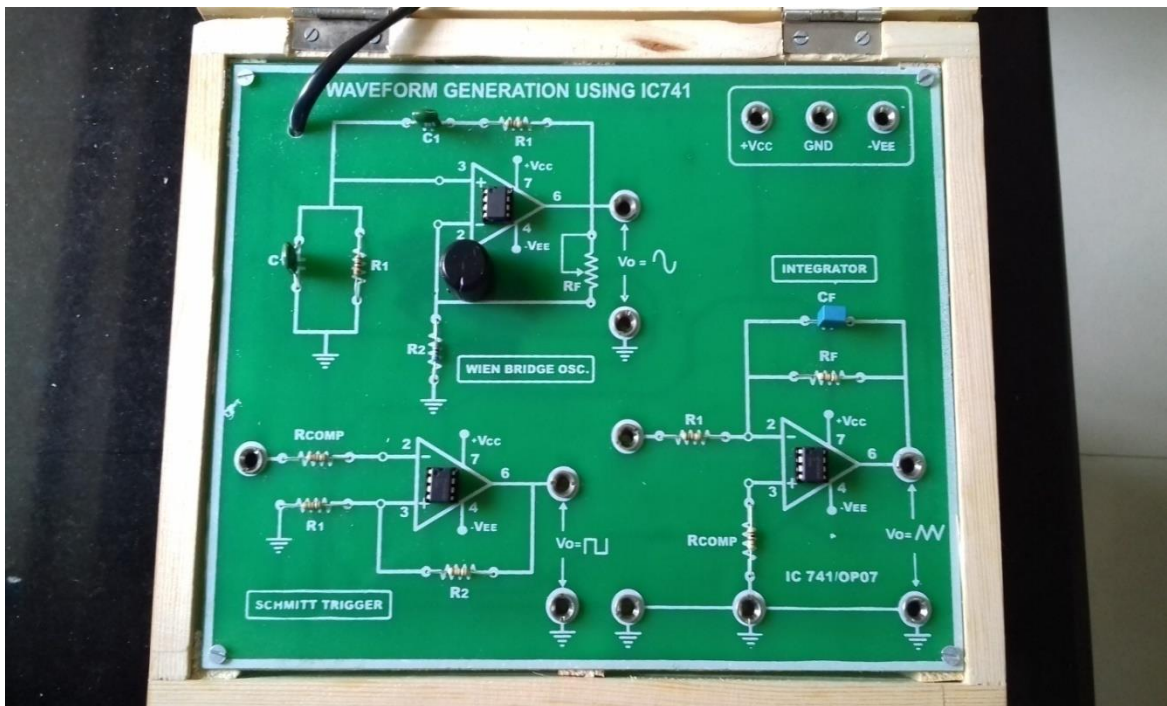

Wien Bridge oscillator

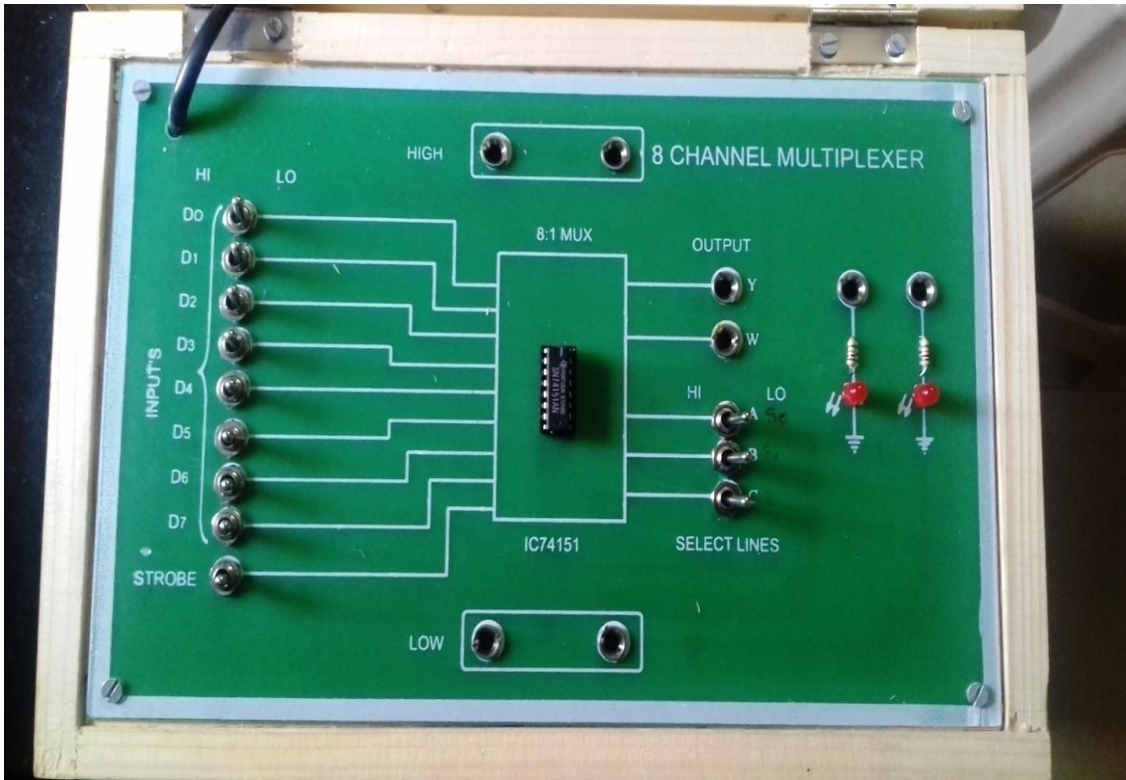

Multiplexer

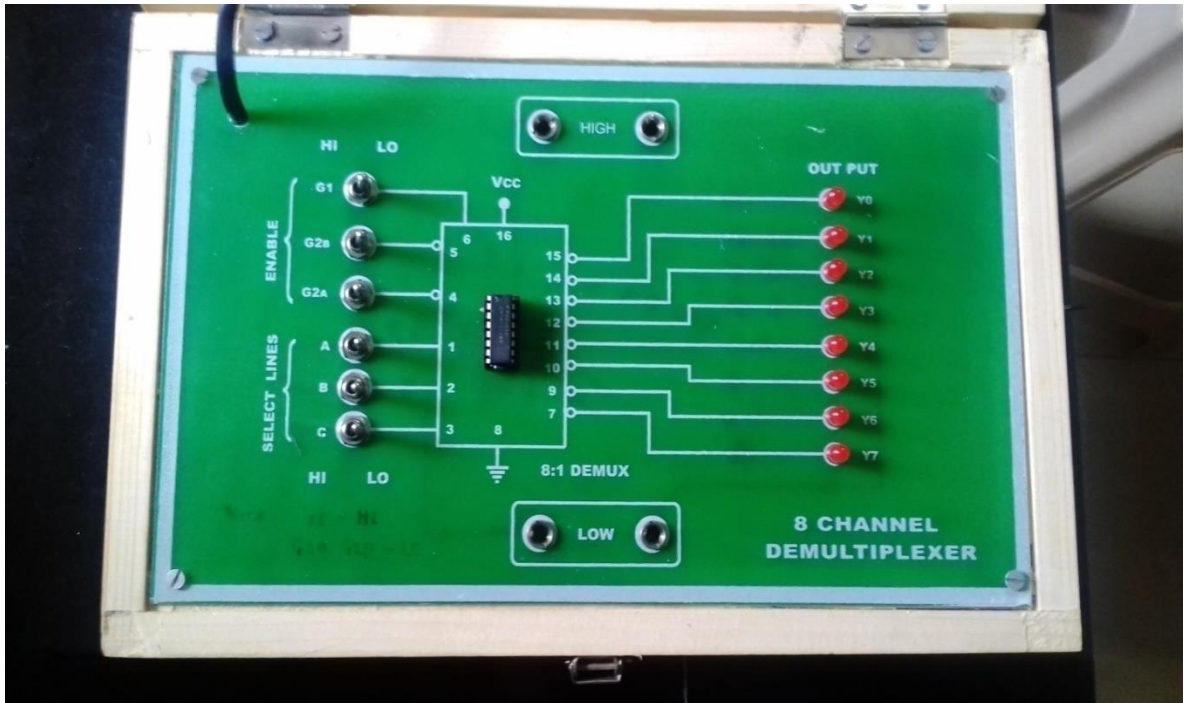

Demultiplexer

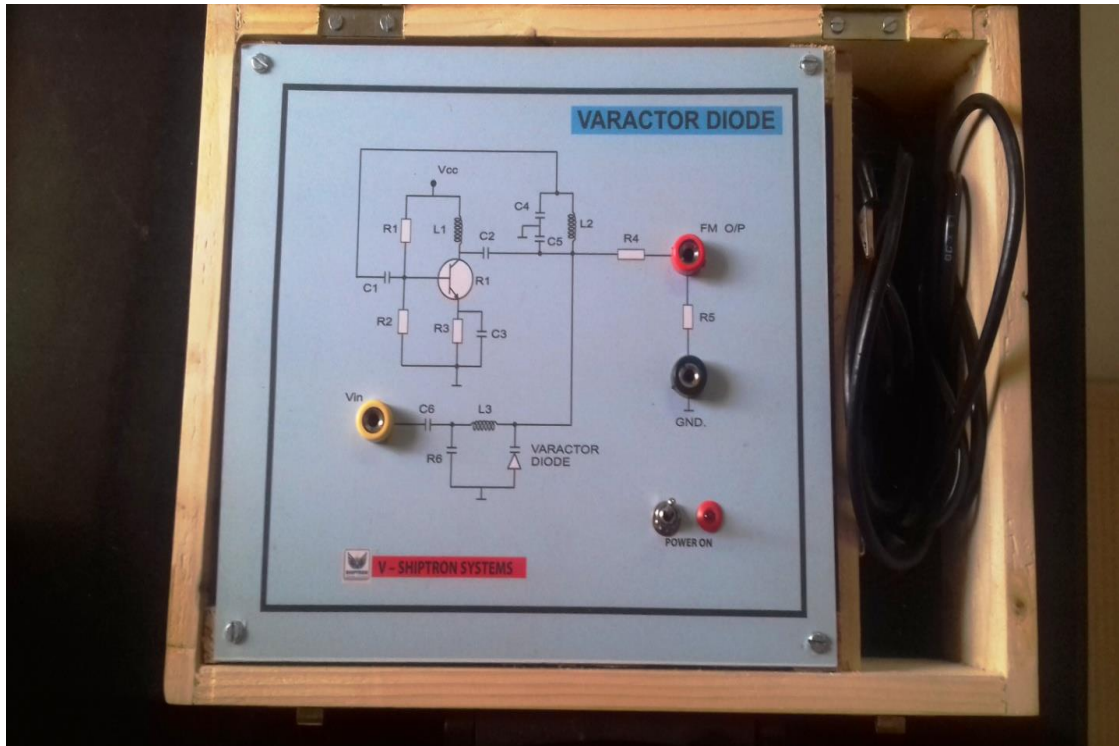

Varactor Diode

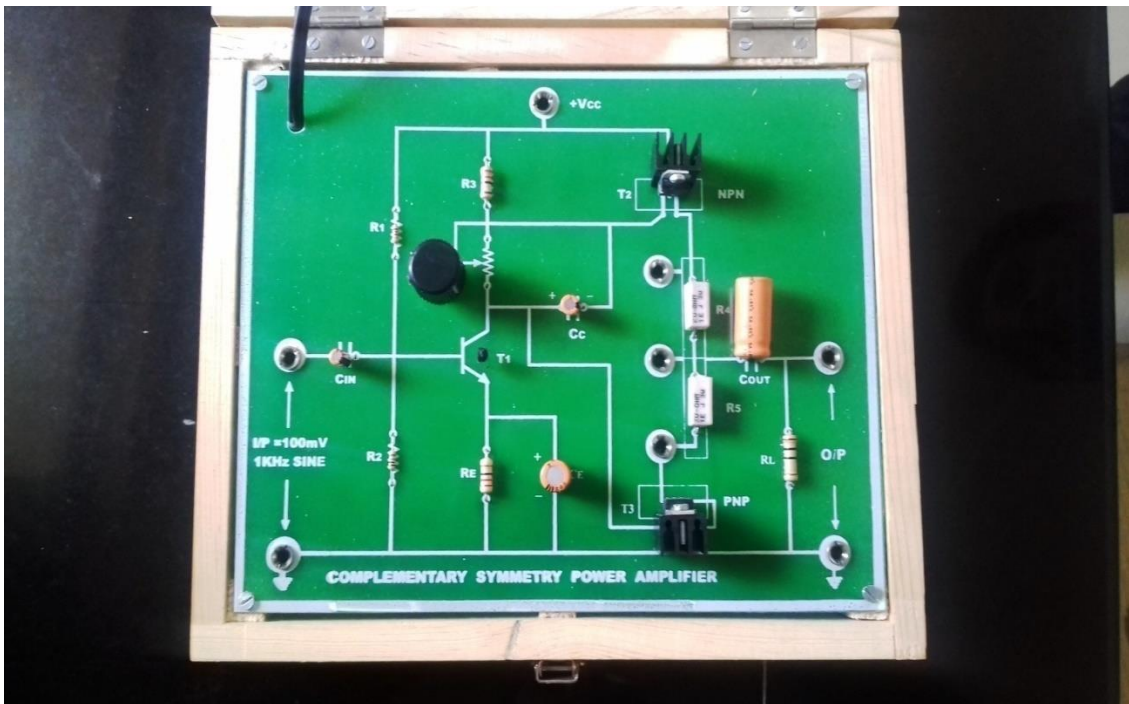

Efficiency of Power Amplifier



Thermionic emission

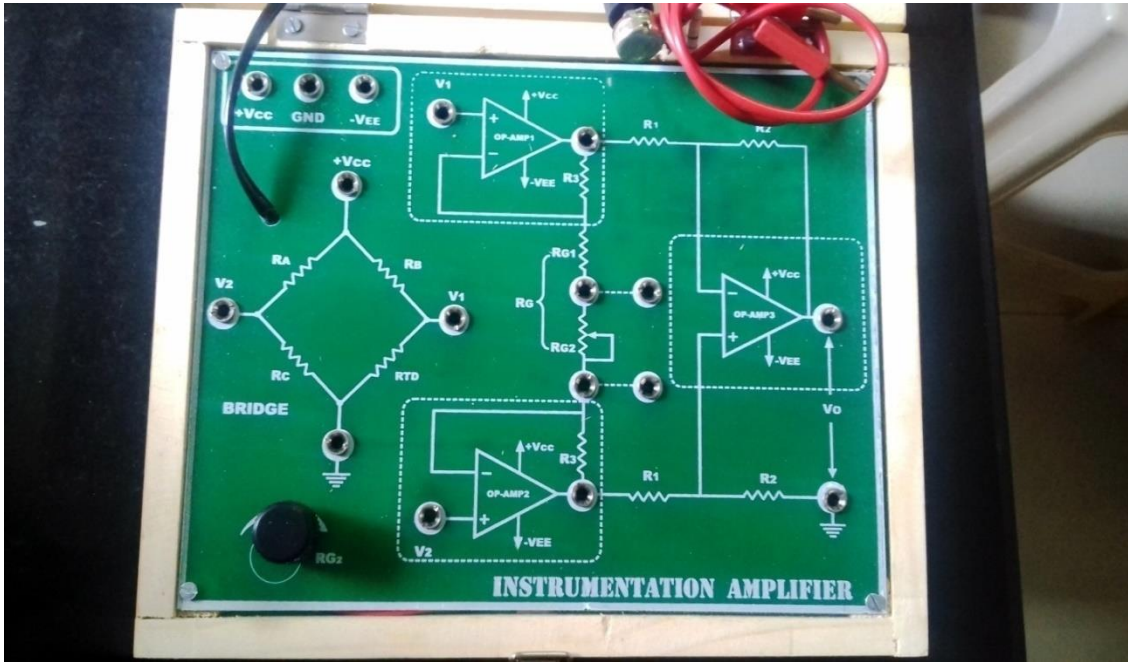

Op-amp as instrumentation amplifier



Function generator with 40MHz frequency



DC power supply 1-30V 2A



Dual power supply 0-30V 2A



CRO 30 MHz

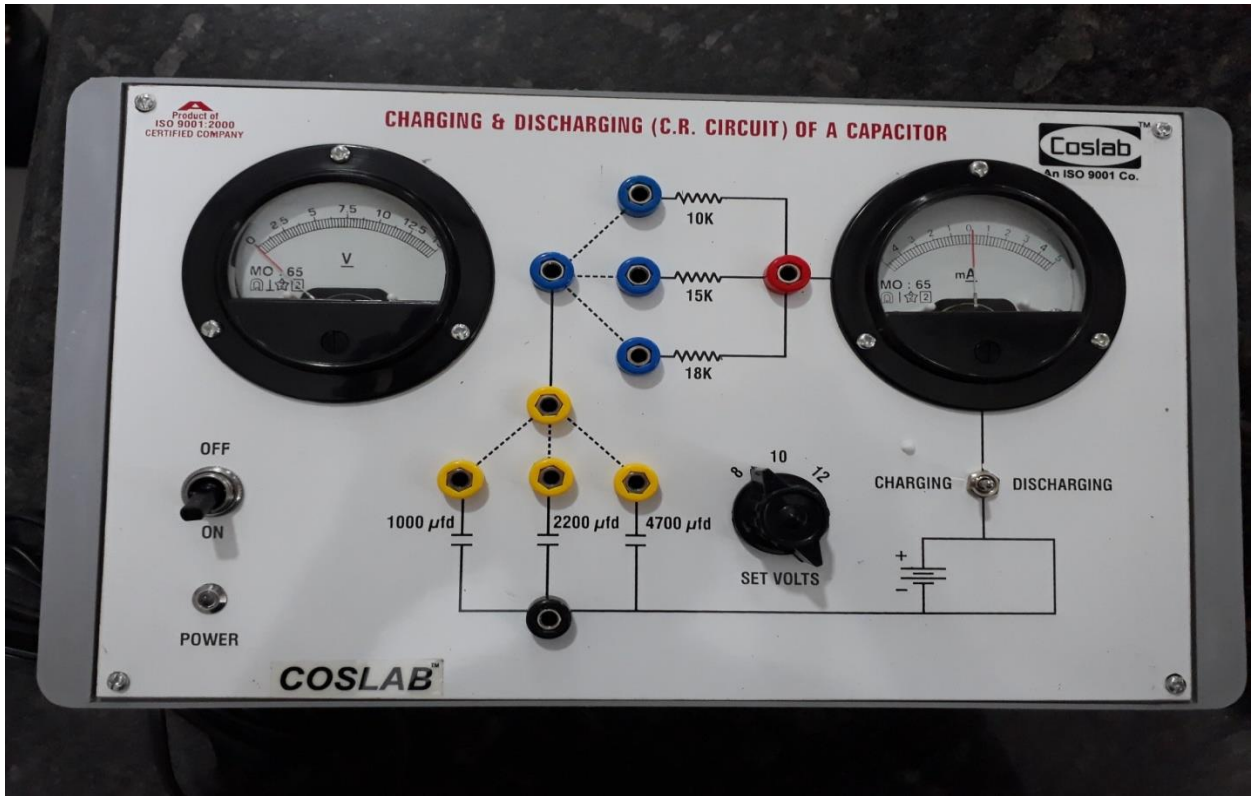

Charging and discharging of capacitor



FET characteristics apparatus

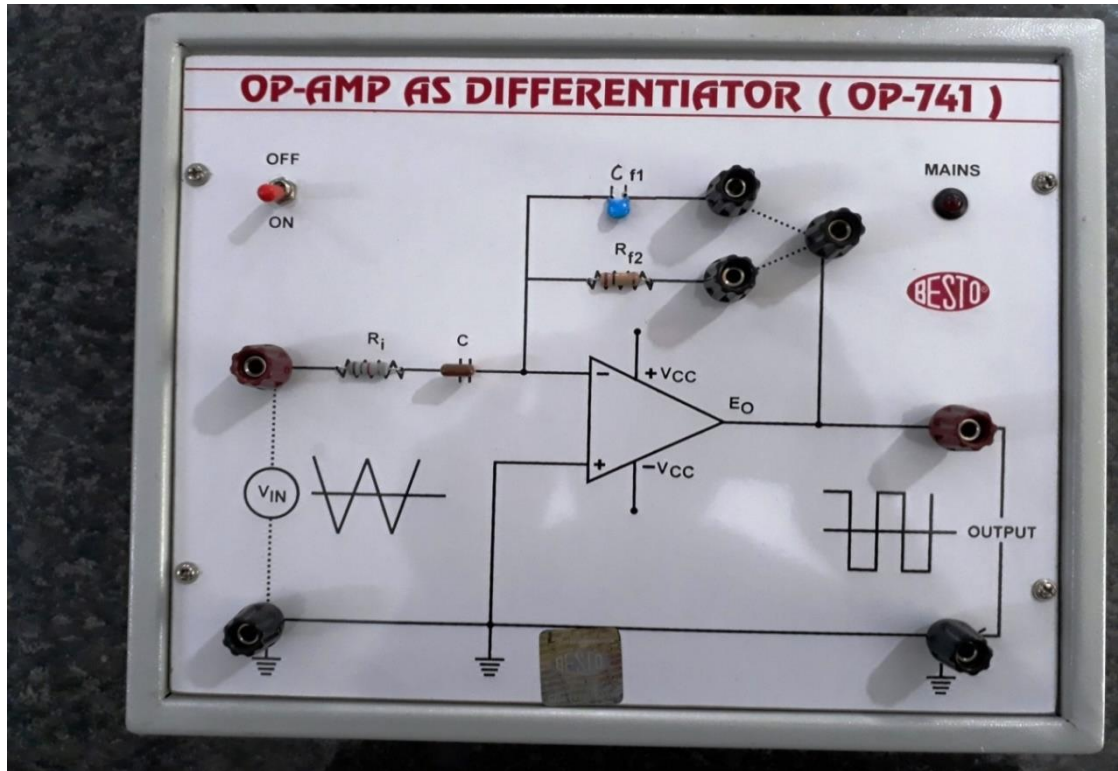

Op-amp as differentiator

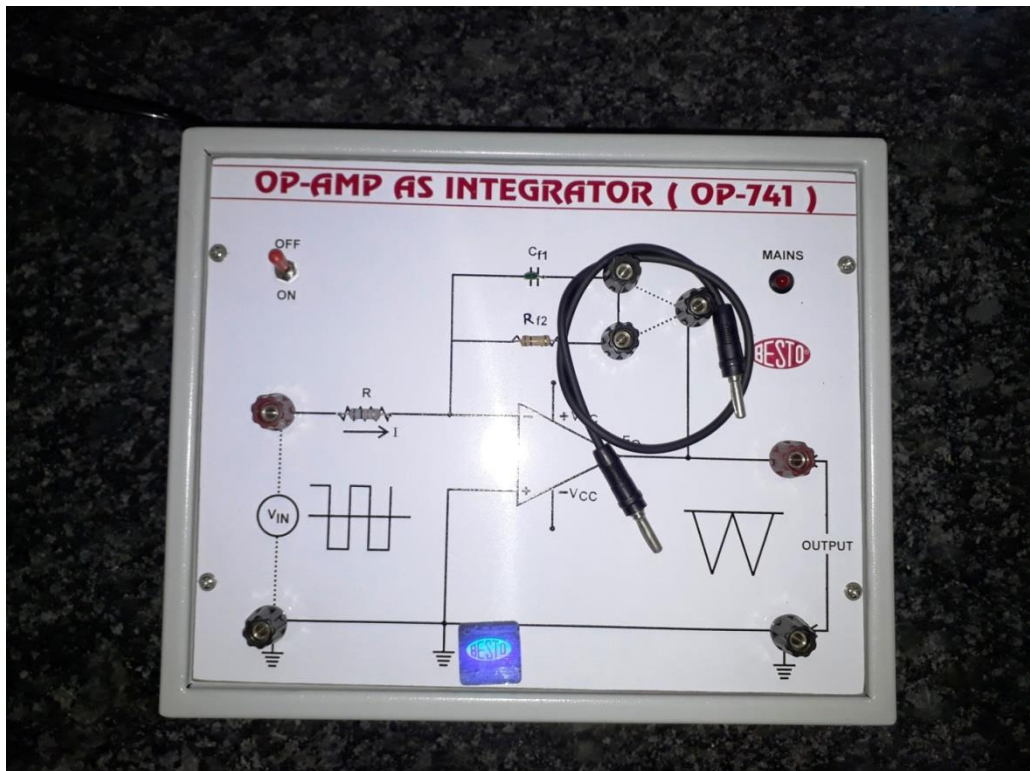

Op-amp as integrator



Oven



Digital Flame Photometer



Analytical Balance



Digital Potentiometer



Muffle Furnace

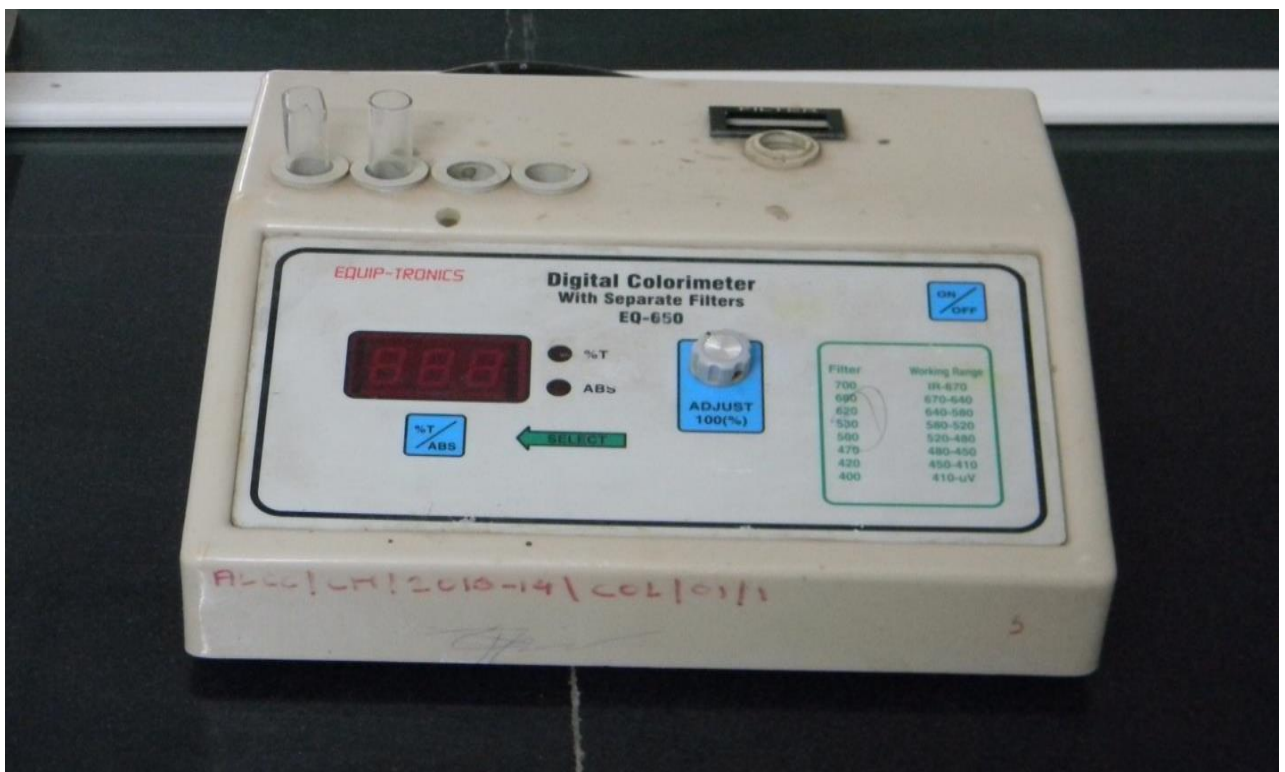

Digital Colorimeter



Conductometer



Photofluorimeter



Nephelo Turbidimeter

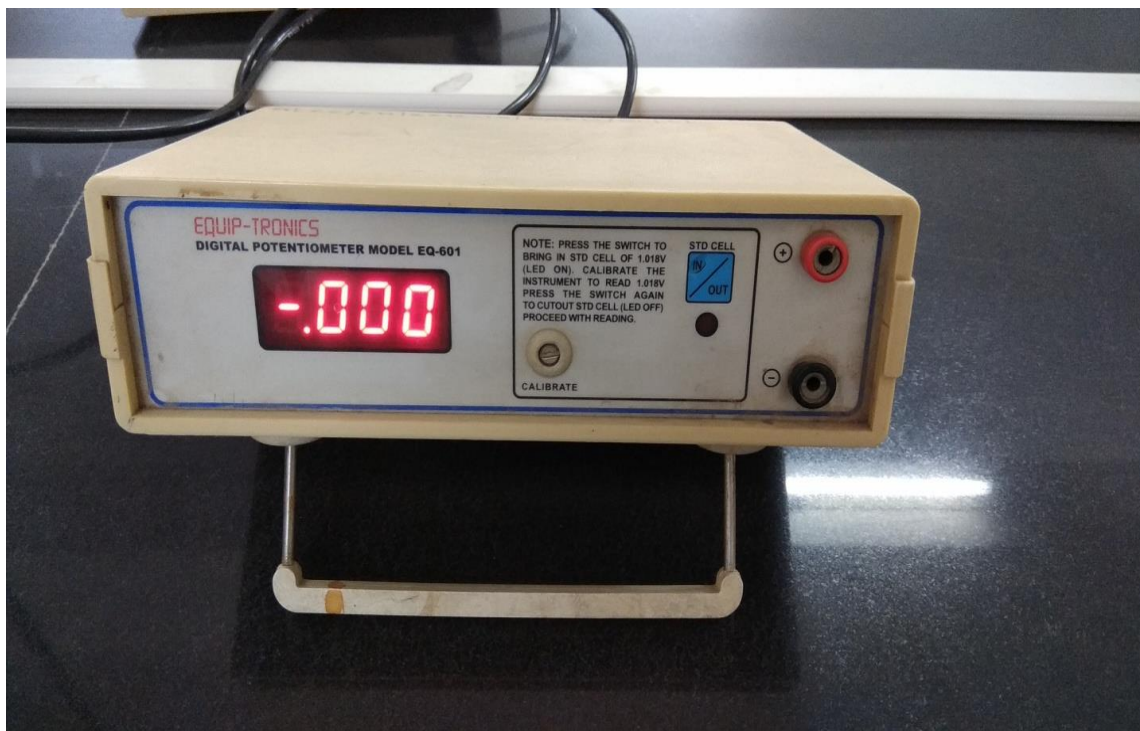

Digital Potentiometer



Abbe Refractometer

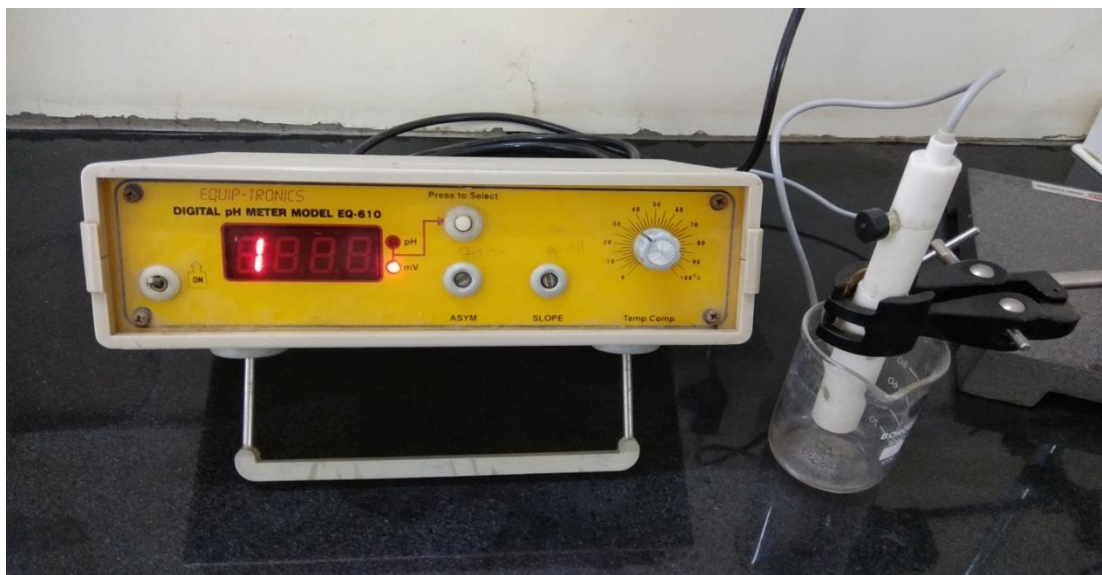

Digital pH meter



Centrifuge



Heating Mantle with energy



Refrigerator



Magnetic Stirrer



Magnetic Stirrer with Hot Plate



UV Cabinet



Round Water Bath



IR Lamp



Water Bath



Digital Magnetic stirrer with hot plate

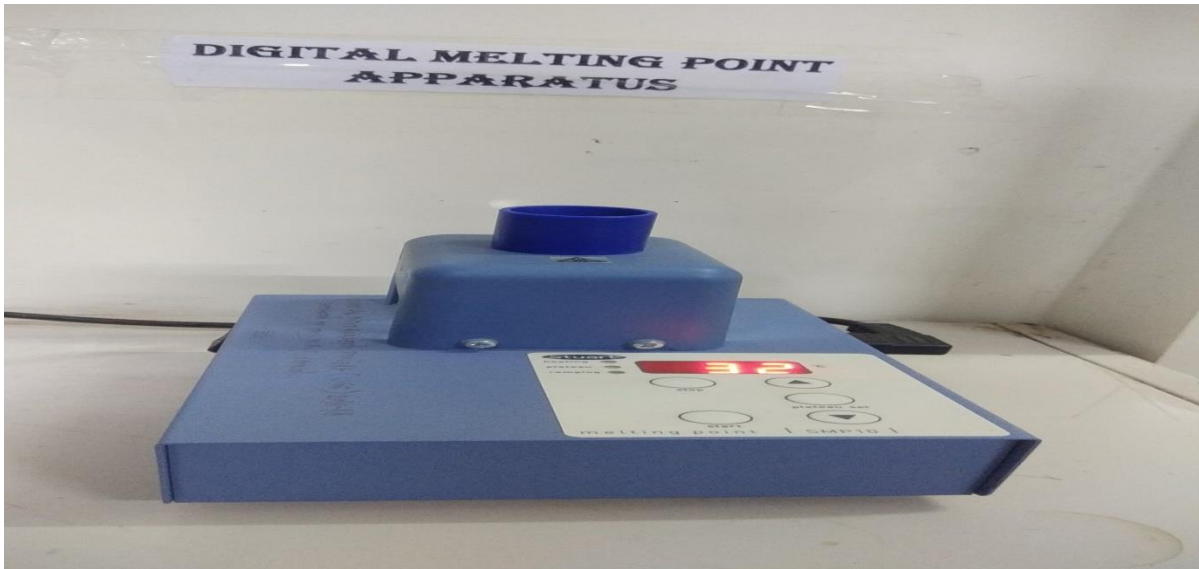

Digital Melting Point Apparatus



Autoclave



Centrifuge



CO₂ Incubator



Industrial Incubator



Laminar Air Flow



Oven



-86°C Deep Freeze



Time: 01-07-2019 12:16
Note: Arts, Commerce and Science College Chandwad

Powered by NoteCam

Refrigerator



Time: 01-07-2019 12:21
Note: Arts, Commerce and Science College Chandwad

Rotary Evaporator



PCR



Waterbath



Honey Comb Sheet



Langstroth Hive Box



DNA Model



Binocular Microscope



Inverted Microscope



Phase Contrast Microscope



Trinocular Inverted Microscope



Plain Table



Prismatic Compass



Dumpy Level



Theodolite



GPS



Body Mass Index

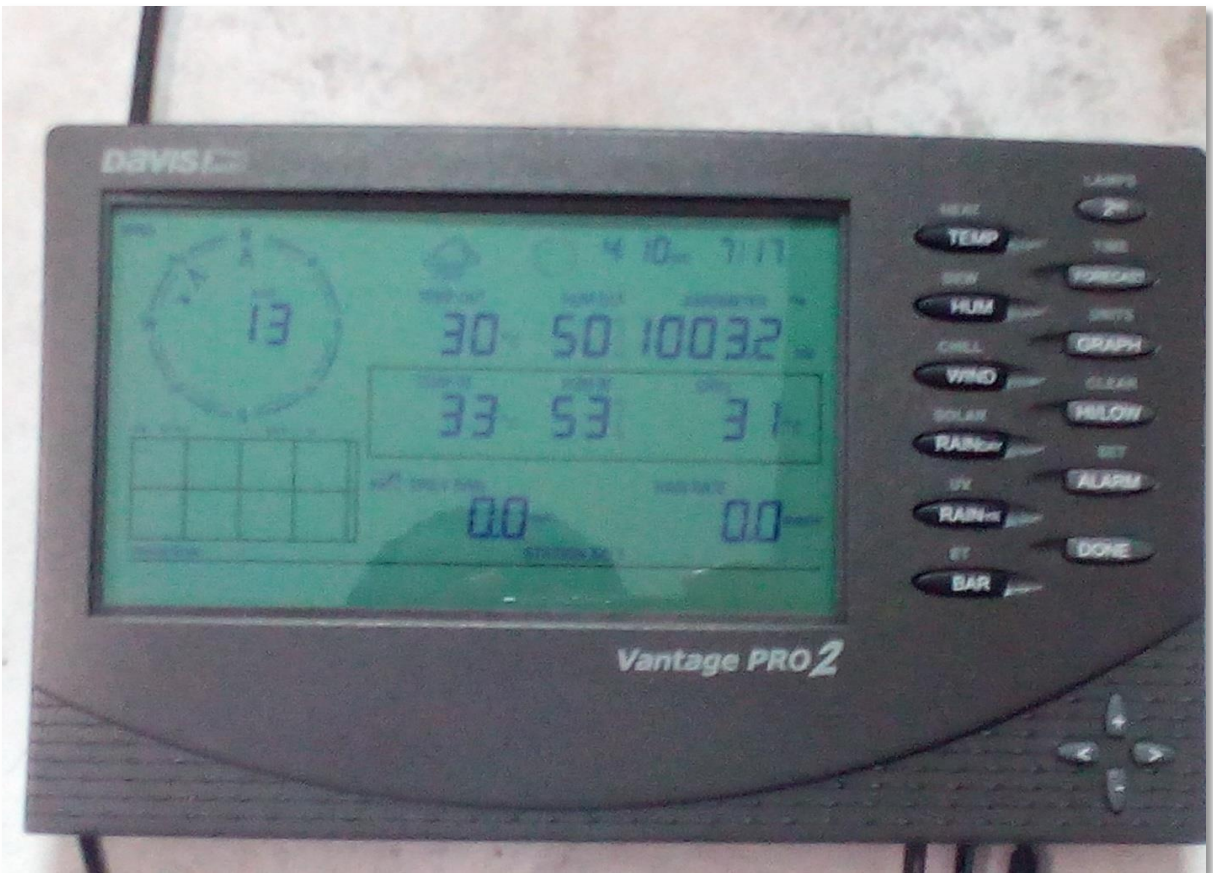

Weather Station



Specimens

Instrument Photo with Caption (Dept. of Botany)

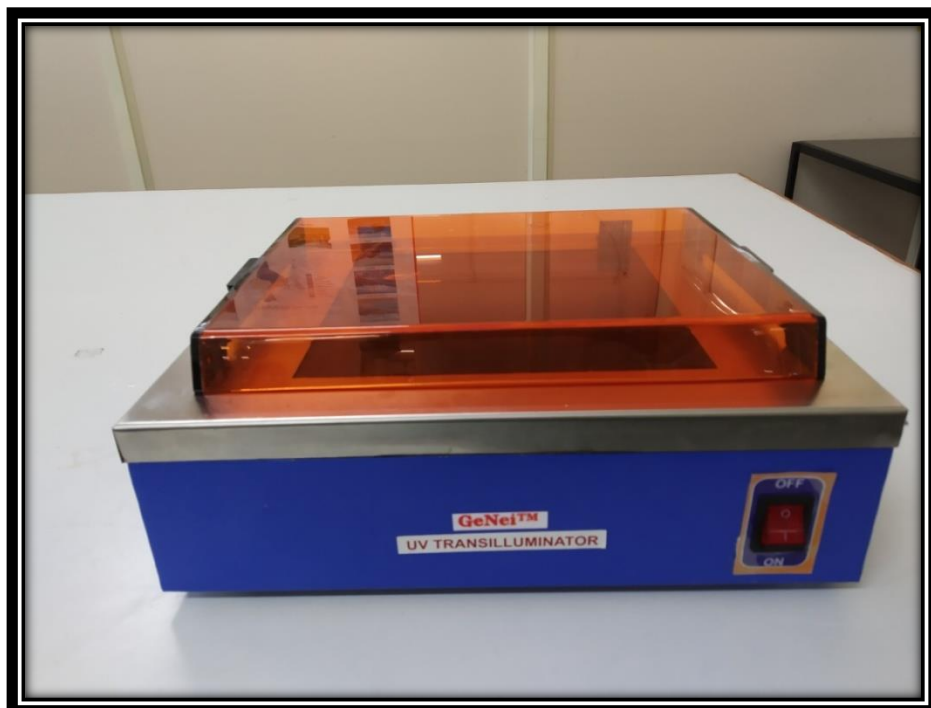

UV Transilluminator



Electronic Microscope LABOMED

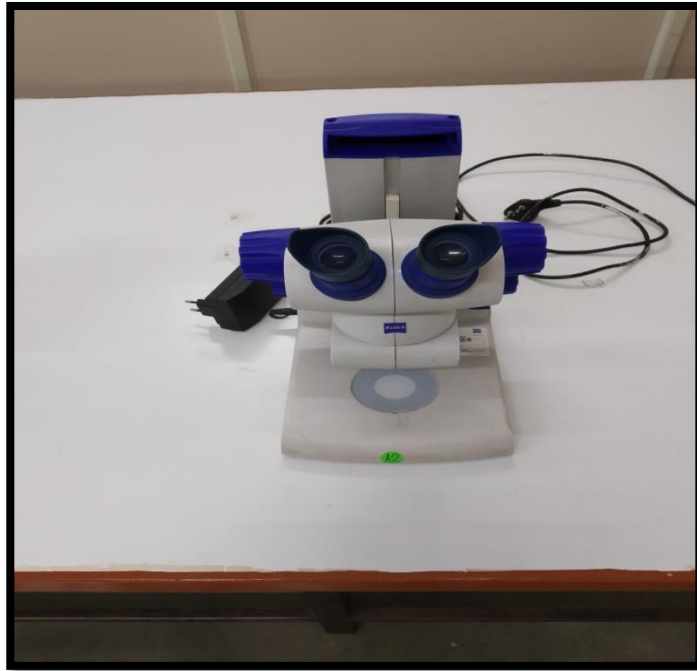

Electronic Microscope (Zeiss)



Electronic Microscope



Power Pack

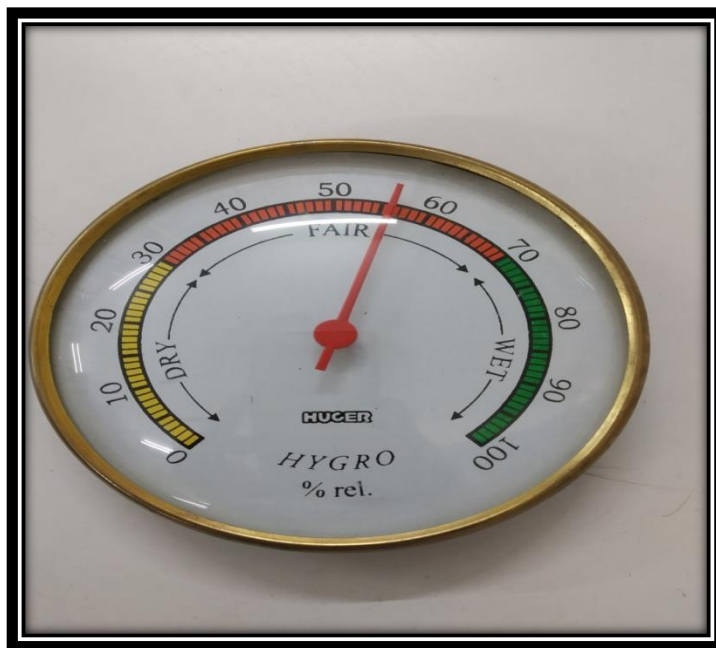

Hygrometer



Camera Lucida(Microscope Unit)

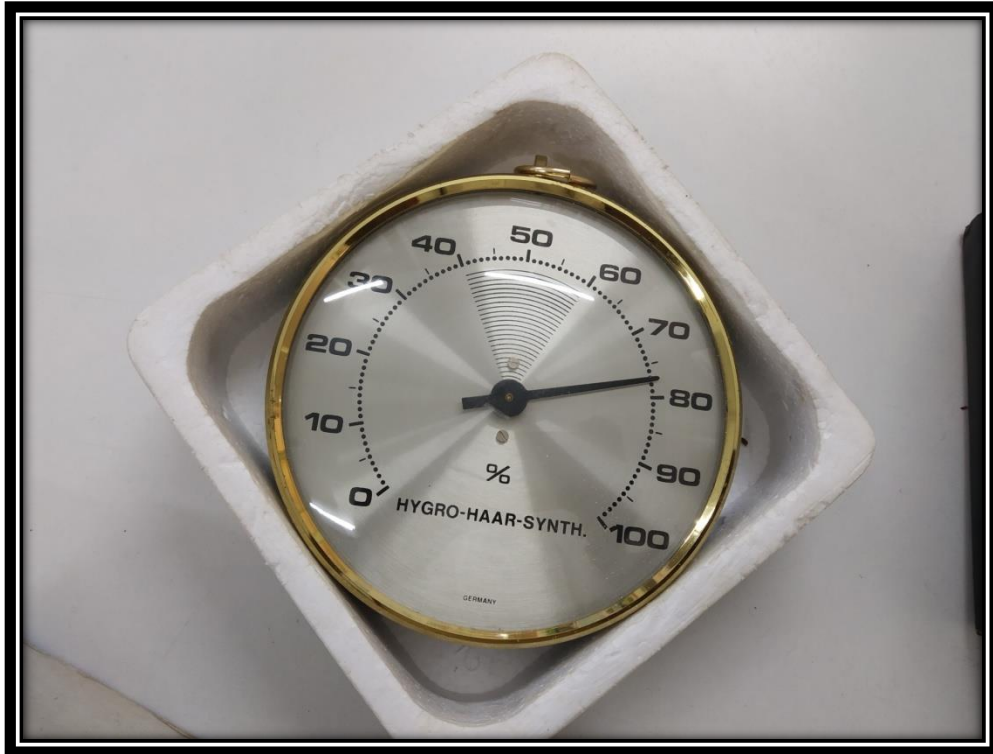

Hygro-Haar-Synthesizer



Spinwin



Centrifuge machine



pH meter



Digital pH meter

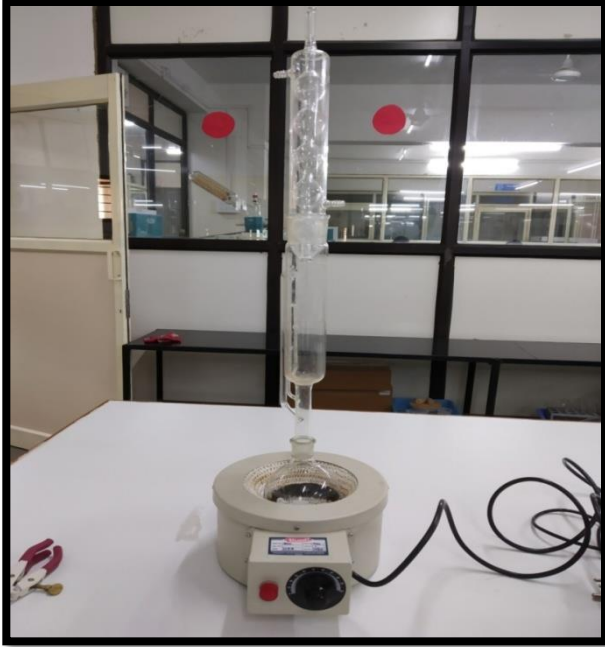

Soxhlet Apparatus



Ocular Micrometer



Soil Analysis Kit



Digital Colorimeter

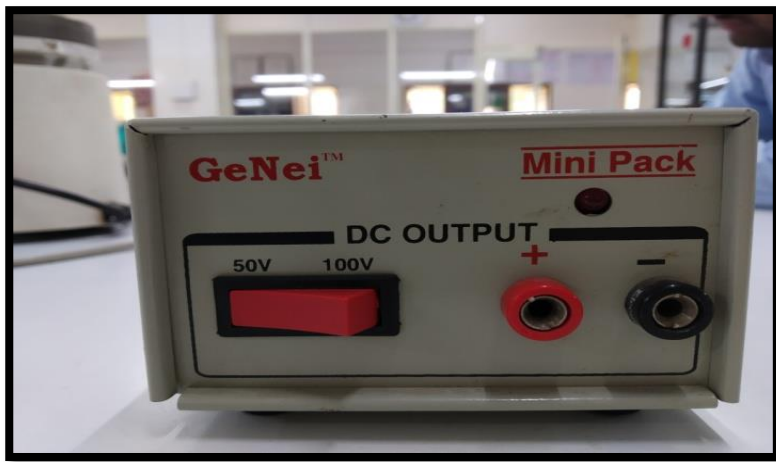
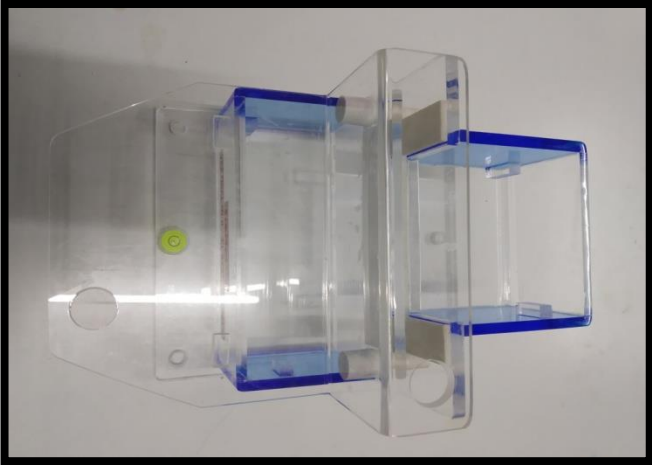

Electrophoresis Kit



Spectrophotometer

Spinwin



Digital Weighing Balance



Autoclave



Hot Air Oven



Water Bath



Roto-Shaker



Electronic weighing Balance



Centrifuge Machine

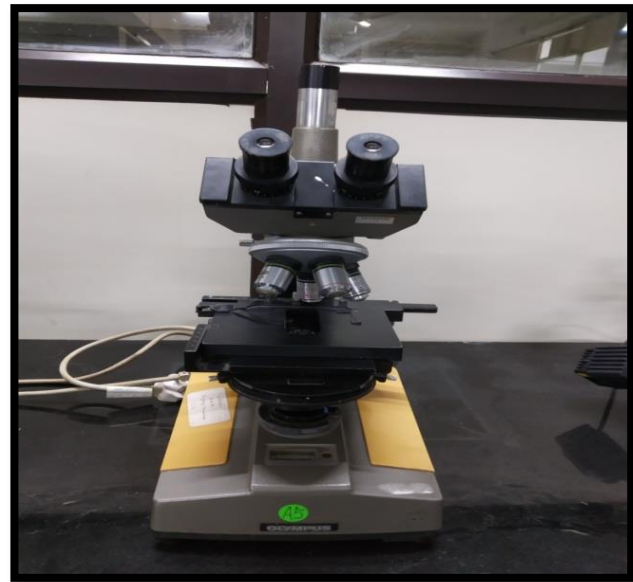

Binocular Microscope(Olympus)

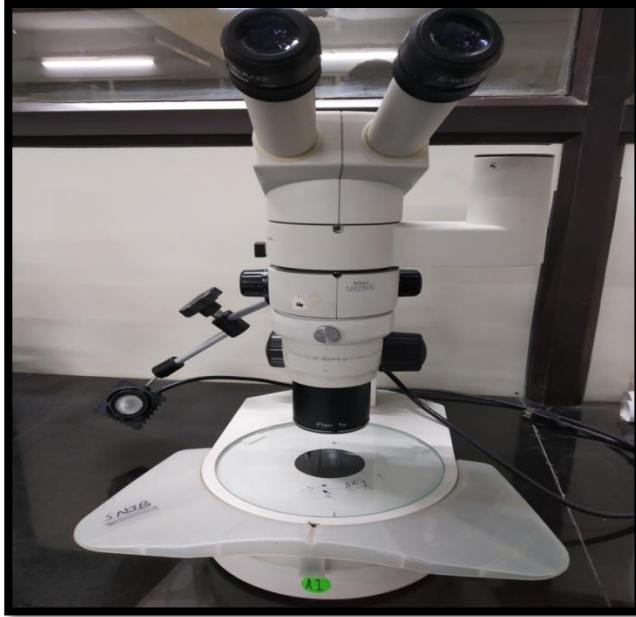

Electronic Binocular Microscope (Nikon)



Rota vapour



Incubator



Vortex

Cyclo Mixe



Vortex Mixer

Cooling Centrifuge



Refrigerator

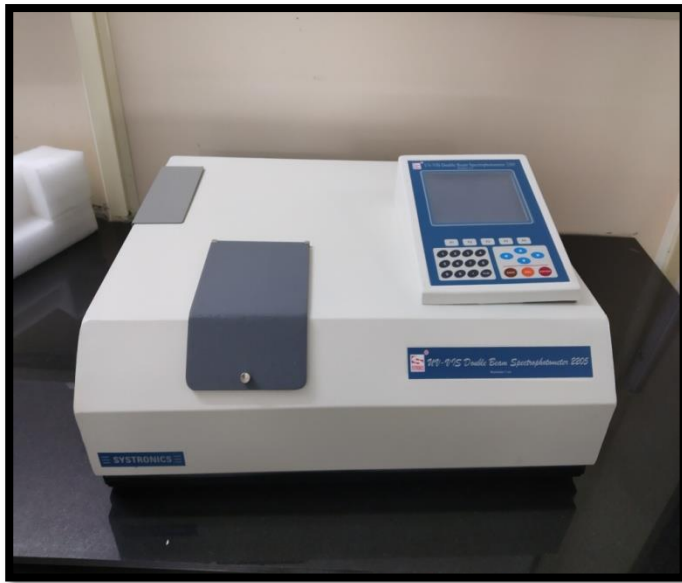

UV Spectrophotometer



Boerner Seed Divider



Purity Work Board



Flame Photometer



Seed Storage Rack



PCR Machine



Vortex



Power Pack Universal Supply



Seed Herbarium Album S-129



Slide Box (5000 Slides)



Laminar Air Flow



Digital moisture Meter



Air Conditioner (A.C.)



LED Transilluminator



Rotary Evaporator



Microtome



Compound Microscope



Dissecting Microscope